

# IntelePACS

4.11.1 and later | DICOM Conformance Statement

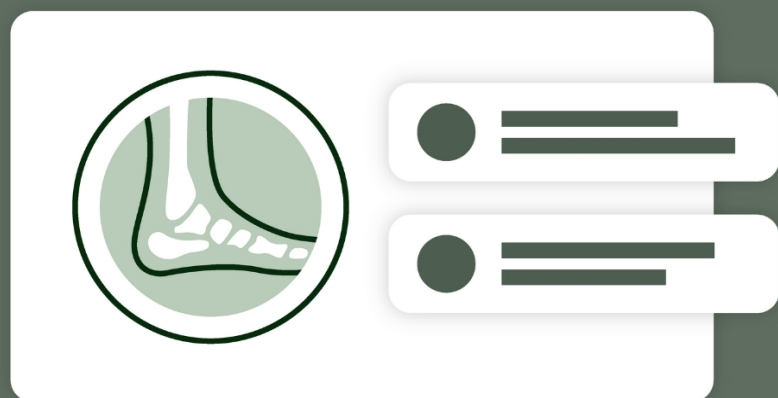

**intelerad**

[intelerad.com](https://www.intelerad.com)

## COPYRIGHT

© 2004-2026 Intelrad Medical Systems Incorporated. All Rights Reserved.

Except as expressly provided otherwise in writing, the information provided in this document is provided AS IS, without any condition or warranty, whether written, oral, express, implied, legal, or statutory. No condition or warranty of merchantability or fitness for a particular purpose applies to anything provided by Intelrad. Without limiting the foregoing, Intelrad nor any of its suppliers warrants this documentation is or will be accurate, error free or meets or will meet user requirements.

## TRADEMARKS

Intelrad®, Intelrad Medical Systems, and the Intelrad logo, IntelePACS®, InteleViewer™, InteleOne®, InteleArchive™, InteleShare VNA™, InteleShare™, InteleShare Research™, InteleOrchestrator™, InteleHeart™, InteleScreen™, and InSight PACS™ are either registered trademarks or trademarks of Intelrad Medical Systems Incorporated or its affiliates.

## THIRD-PARTY TRADEMARKS

Adobe, Acrobat, and Reader are either registered trademarks or trademarks of Adobe Systems Incorporated in the United States and/or other countries. Firefox is a registered trademark of Mozilla Foundation in the United States and other countries. Google Chrome browser is a registered trademark of Google Inc. in the United States and other countries. Internet Explorer is a registered trademark of Microsoft Corporation in the United States and other countries. Intel, Pentium, Pentium II Xeon, and Pentium III Xeon are trademarks or registered trademarks of Intel Corporation or its subsidiaries in the United States and other countries. Microsoft and Windows are either registered trademarks or trademarks of Microsoft Corporation in the United States and/or other countries. NVIDIA is a trademark or registered trademark of NVIDIA Corporation in the United States and/or other countries. Oracle and Java are registered trademarks of Oracle Corporation and/or its affiliates. PowerScribe 360 is a trademark or registered trademark of Nuance Communications Inc. or its affiliates in the United States and/or other countries. Sun, Sun Microsystems, and Java are trademarks or registered trademarks of Sun Microsystems, Inc. in the United States and other countries. Safari, Mac, and OS X are trademarks of Apple Inc., registered in the United States and other countries.

All other brand names, product names, or trademarks belong to their respective holders.

## PERFORMANCE CHARACTERISTICS

- Customizable reading and reporting workflow for each user
- Built in redundancy and backup to support continuity of clinical operations
- Image resolution
- Integration with Electronic Health Records (EHR)
- Reliability and ease of use
- Image and data integrity
- Remote access
- High performance image management
- Optimizes workflow efficiency by reducing turnaround times
- Reduce film and storage costs

## CLINICAL BENEFITS

- Improved diagnostic accuracy
- Increased speed and quality of reporting

## INTENDED USE/INDICATIONS FOR USE

IntelePACS is a software application that receives digital images and data from various sources (such as CT scanners, MR scanners, ultrasound systems, R/F units, computer and direct radiographic devices, secondary capture devices, scanners, imaging gateways, or other imaging sources). Images and data can be communicated, processed, manipulated, enhanced, stored, and displayed within the system and/or across computer networks at distributed locations. Post-processing of the images can be performed using Multi Planar Reconstruction (MPR).

Only preprocessed DICOM for presentation images can be interpreted for primary image diagnosis in mammography. Mammographic images with lossy compression and digitized film screen images must not be reviewed for primary image interpretations.

Mammographic images may only be interpreted using an FDA cleared display that meets technical specifications reviewed and accepted by regulatory authorities.

For Canada, United States, Europe, Australia, New Zealand, and South Africa only: When used with a mobile device, IntelePACS is suitable for diagnostic image review

only on tested devices as specified in Intelrad product documentation. IntelePACS is not intended for primary diagnostic image review on mobile devices. Mobile usage for Mammography is for reference and referral only.

For all other countries: IntelePACS is not intended for diagnostic image review on mobile devices. Mobile usage for Mammography is for reference and referral only.

IntelePACS displays measurements in cm, square cm, and cubic cm units of measure when the appropriate DICOM attributes in the image are available, or you have applied a manual calibration. Otherwise, the units of measure are pixels, square pixels, and cubic pixels.

## EXPECTED LIFE

IntelePACS software. The lifetime of the product is approximately 3 to 4 years. Software is fully supported during its defined lifetime. Intelrad may require that clients' systems be upgraded to the latest configuration available past the end of life of software.

CONTRAINDICATIONS—None.

WARNINGS — None

CAUTIONS — see Residual Risk section

This system does not replace the education, skill, and judgment of properly trained medical practitioners. Only properly trained and qualified individuals shall have access to and use IntelePACS and must know of its functionality, capabilities and limitations.

**INTENDED USERS** - Typical users of this system are trained health professionals, physicians, nurses, and technologists.

Downloaded Images, Workstations and Isolated Installs: You and your users must maintain IntelePACS with the most current versions, including available updates and upgrades. Delaying or refusing updates or upgrades following a recall may result in a non-compliant IntelePACS.

NOTICE —

IntelePACS is a medical device, and as such, must meet medical device safety and effectiveness requirements imposed by national regulations. Any unmonitored or unconnected use of IntelePACS, or use of IntelePACS without a valid right may put the health and safety of patients at risk as you will not be advised of the availability of any software patch, bug fix, update or upgrade nor will be informed of Field Safety Notices, Medical Device Recalls or Advisory Notices related to IntelePACS. Client and authorized users will be informed of Field Safety Notices, Medical Device Recalls or Advisory notices if they are impacted. Clients may also consult national regulatory site (s) to be informed of Field Safety Notices, Medical Device Recalls, or Advisory Notices related to IntelePACS that do not impact the client. Intelrad does not have access to authorized users' systems to implement corrections to prevent (or correct) occurrences of patient safety issues. When a correction is available Clients will be informed and must authorize Intelrad to upgrade their systems. You are responsible to flow down recall and patient safety information to your users. The user of the medical device must report any serious incident that has occurred in relation to the medical device to the manufacturer (Intelrad) and the competent authority having jurisdiction in their locale. The user of the medical device must report any serious incident that has occurred in relation to the medical device to the manufacturer (Intelrad) and the competent authority having jurisdiction in their locale.

The user of the medical device must report any serious incident that has occurred in relation to the medical device to the manufacturer (Intelrad) and the competent authority having jurisdiction in their locale.

USA: Report adverse events to the manufacturer and FDA at [www.fda.gov/medwatch](http://www.fda.gov/medwatch).

European Union: Any serious incident that has occurred in relation to the device should be reported to the manufacturer and the competent authority of the Member State in which the user and/or patient is established.

PATIENT DATA DELETION REQUESTS: To fully delete patient data upon data subject request, please reach out to our Support department through the Service Portal.





Intelrad Medical Systems Incorporated  
800, boul. De Maisonneuve East, 14th floor  
Montreal (Quebec)  
H2L 4L8 Canada



**EMERGO EUROPE**

Westervoortsedijk 60,  
6827 AT Arnhem  
The Netherlands



**UK RESPONSIBLE PERSON**

Emergo Consulting (UK) Limited  
c/o Cr360 - UL International  
Compass House, Vision Park Histon  
Cambridge CB24 9BZ  
United Kingdom

**AUSTRALIAN SPONSOR**

Emergo Australia  
Level 20, Tower II, Darling Park, 201 Sussex Street  
Sydney, NSW 2000, Australia



<https://serviceportal.intelerad.com/csm>

A paper copy of the IFU is available upon request at no additional cost.

Title: IntelePACS DICOM Conformance Statement  
# 4.11.1 and later (Multiple Patient Multiple Use)  
Date: 2026-05-13  
Part number: IPDENCNF-O Issue 020

# TABLE OF CONTENTS

<b>Document Revisions</b> .....	<b>8</b>
<b>Document Conventions</b> .....	<b>11</b>
<b>Residual Risks</b> .....	<b>13</b>
<b>Introduction</b> .....	<b>15</b>
<b>Abbreviations and Acronyms</b> .....	<b>17</b>
<b>Implementation Model</b> .....	<b>18</b>
Application Data Flow Diagram .....	18
Functional Definition of Application Entities .....	18
Modality Server AE .....	19
Verification .....	19
Storage .....	19
Storage Commitment .....	20
Query/Retrieve .....	21
Automatic Routing .....	22
Acquisition (DICOM) Prefetching .....	23
Master/Modality Server AE .....	23

Verification .....	23
Storage .....	23
Storage Commitment .....	23
Query/Retrieve .....	23
Automatic Routing .....	24
Acquisition (DICOM) Prefetching .....	25
Master Database/Web Server AE .....	25
Verification .....	25
Store-and-Forward .....	25
Query/Retrieve .....	26
Robotics Server AE .....	27
Verification .....	27
Query/Retrieve .....	27
Archive Cache Server AE .....	27
Verification .....	27
Storage .....	27
Query/Retrieve .....	28
RIS Interface Gateway AE .....	28
Verification .....	28
Modality Worklist .....	28
Modality Performed Procedure Step .....	29
Sequencing of Real-World Activities .....	30
<b>IntelPACS AE Specifications .....</b>	<b>31</b>
Association Establishment Policies .....	35
General .....	35
Number of Associations .....	35
Asynchronous Nature .....	36

Implementation Identifying Information .....	36
Association Initiation Policy .....	36
Real-World Activity—Move Request From an External Node .....	36
Associated Real-World Activity—Move Request From an External Node .....	36
Proposed Presentation Contexts .....	37
SOP Specific Conformance—Move Request from an External Node .....	39
Real-World Activity—DICOM Prefetching .....	40
Associated Real-World Activity—DICOM Prefetching .....	40
Proposed Presentation Contexts .....	40
SOP Specific Conformance—DICOM Prefetching .....	40
Real-World Activity—DICOM Modality Performed Procedure Step .....	41
Associated Real-World Activity—DICOM Modality Performed Procedure Step .....	41
Proposed Presentation Contexts .....	41
Association Acceptance Policy .....	41
Real-World Activity—Storage .....	42
Associated Real-World Activity—Storage .....	42
Presentation Context Table .....	43
SOP Specific Conformance—Storage .....	63
Presentation Context Acceptance Criterion .....	64
Transfer Syntax Selection Policies .....	64
Real-World Activity Query/ Retrieve .....	65
Associated Real-World Activity—Query/Retrieve .....	65
Presentation Context Table .....	65
SOP Specific Conformance for SOP Class Query/Retrieve .....	66
Presentation Context Acceptance Criterion .....	69
Transfer Syntax Selection Policies .....	69
Real-World Activity Verification .....	69

Associated Real-World Activity—Verification .....	69
Presentation Context Table .....	70
SOP Specific Conformance—Verification .....	70
Presentation Context Acceptance Criterion .....	70
Transfer Syntax Selection Policies .....	70
Real-World Activity—Storage .....	70
Associated Real-World Activity—Storage .....	70
Presentation Context Table .....	72
SOP Specific Conformance—Storage .....	72
Presentation Context Acceptance Criterion .....	73
Transfer Syntax Selection Policies .....	73
Real-World Activity Modality Worklist .....	73
Associated Real-World Activity—Modality Worklist .....	73
Presentation Context Table .....	74
SOP Specific Conformance—Modality Worklist .....	74
Presentation Context Acceptance Criterion .....	75
Transfer Syntax Selection Policies .....	75
<b>Communication Profiles .....</b>	<b>76</b>
TCP/IP Stack .....	76
TCP/IP API .....	76
Physical Media Support .....	76
<b>Extensions/Specializations/Privatizations .....</b>	<b>77</b>
<b>Obtaining Printed Documentation .....</b>	<b>78</b>
<b>Contacting Intelrad Technical Support .....</b>	<b>79</b>
<b>System Requirements .....</b>	<b>81</b>

# DOCUMENT REVISIONS

Revision	Date	Author	Comments
1	2003-05-01	Robert Cox	Initial revision.
2	2003-11-17	Kent Tse	Added 3 table entries in the SOP classes.
3	2004-07-30	Jason Bechervaise	Updated SOP Class UID tables, updated PACS version.
4	2004-08-10	Kent Tse	Updated SOP classes and Acceptable Presentation Contexts tables.
5	2005-02-15	Kent Tse	Added new Key Object Selection SOP class for PACS 2.6.1 and above.
6	2005-12-12	Kent Tse, Susan Daoud	Full document revision, as applicable to IntelPACS version 3.2.2 and later.
7	2006-02-20	Susan Daoud	Added Explicit VR Little Endian Transfer Syntax UIDs.
8	2007-03-12	Kent Tse, Irene Plokar	Added JPEG Baseline (Process 1) and JPEG Extended (Process 2,4) transfer syntaxes, and updated JPEG Lossless transfer syntax.
9	2008-08-29	Kent Tse	Added Structured Report SOP classes for SCP and SCU.
Issue 001	2008-10-24	Marc Paquette	Changed document version from 2.6 to IPDENCNF-O Issue 001.
Issue 002	2010-10-26	Fabio de Oliveira	Updated for IntelPACS 4.2.1 (Enhanced CT, Mammography, MPEG2, YBR, JPEG, and RLE).



Revision	Date	Author	Comments
		Padilha, Marc Paquette	Corrected Ethernet measurement units. Updated to use new branding.
Issue 003	2011-12-09	Fabio de Oliveira Padilha, Marc Paquette, Irene Plokar	Updated section 4.2.1.1, " <a href="#">Real-World Activity—Move Request From an External Node</a> " on page 1" to clarify the processing of CMOVE requests on a Master Database/Web Server. Also updated Table 8 to include the RequestedProcedureID key for Study Root queries. Added information on MPPS support. Added a Table of Contents.
Issue 004	2014-03-07	Nick Cabatoff, Fabio de Oliveira Padilha, Marc Paquette	Added section " <a href="#">Master/Modality Server AE</a> " (page 23), "Master/Modality Server AE." Clarified section " <a href="#">Number of Associations</a> " (page 35), "Number of Associations." Added Breast Tomosynthesis Image Storage to section " <a href="#">IntelePACS AE Specifications</a> " (page 31), "IntelePACS AE Specifications." Updated table "Acceptable Presentation Contexts for an IntelePACS Server—Storage."
Issue 005	2015-05-12	Marc Paquette	Added image bit depths that are supported. Added Multi-frame Grayscale Word Secondary Capture Image Storage, Color Softcopy Presentation State Storage, and X-Ray Radiation Dose SR SOP classes for SCU and SCP.
Issue 006	2016-09-09	Irene Plokar, Fouad Zaryouh	Added Enhanced MR Image Storage, Raw Data Storage, and Encapsulated PDF Storage classes for SCP and SCU.
Issue 007	2017-03-17	Irene Plokar	Updated the cover page and headers with Intelrad's recent corporate logo.
Issue 008	2018-08-24	Roberta Boyle	Includes updates for the following SOP Class: Video Endoscopic Image Storage. Updated the following transfer syntaxes: MPEG-4 AVC/H.264 High Profile and MPEG-4 AVC/H.264 BD-compatible High Profile.
Issue 009	2018-09-25	Kathleen Jette	Changed sentence in topic "4.3.1.2 Presentation Context Table" under Table 4: Acceptable Presentation Contexts for an IntelePACS Server—

Revision	Date	Author	Comments
			Storage to include images with 32 bits allocated.  Added note under Table 4: Acceptable Presentation Contexts for an IntelePACS Server—Storage stating images with 32 bits allocated cannot be archived to tape.
Issue 010	2019-10-28	Luca Cogliandro	Added a manufacturer icon, and changed the date format, in the Copyright page.
Issue 011	2019-10-29	Yavor Petkov	Added 12-lead ECG Waveform Storage to the IntelePACS AE Specifications table.
Issue 012	2020-11-16	Janetta McCreery, Mark Groves	Updates for IntelePACS 5.3.1 release.
Issue 013	2021-11-18	Gauri Kulkarni, Mark Groves	Added Breast Projection X-Ray Image Storage - For Presentation to the AE Specifications table for IntelePACS 5.5.1 release.
Issue 014	2023-02-26	Krishnali Kondekar	Removed the CE Mark.
Issue 015	2023-07-26	Abhiruchi Gaikwad	Added the UKCA Mark.
Issue 016	2024-05-14	Abhiruchi Gaikwad	Updated the project per rebranding guidelines.
Issue 017	2025-03-24	Abhiruchi Gaikwad	Added Enhanced MR Color Storage to the Presentation Context Table for IntelePACS Server - Storage.
Issue 018	2025-04-07	Abhiruchi Gaikwad	Updated the dates in the document per the format specified in IFU Product Labeling.
Issue 019	2025-09-12	Abhiruchi Gaikwad	Reimplemented CE Mark
Issue 020	2026-02-16	Shruti Bhende	Updated SOP Classes













# DOCUMENT CONVENTIONS

Several conventions are used throughout this document. A list of these and examples of their use are provided below.

## Typographic Convention

Convention	Example
Text that you enter in a field, or on a command line are in <code>courier</code> font.	In the Date field, enter 2003/04/04.
Keyboard commands are in <b>SMALL CAPS AND BOLD</b> .	Press <b>CTRL+C</b> to copy text.
New terminology or concepts are <i>italicized</i> .	The process of automatically distributing the images is referred to as <i>autorouting</i> .
Interface elements, such as menus, buttons, options, and preferences are <b>bold</b> .	From the <b>Font</b> list, choose the desired font.
Menu selections are separated by vertical lines.	Choose <b>File   Print</b> to print this page.
Information that is important for a user to know when performing a task, such as prerequisite information or restrictions, is represented with a note icon .	 To view reports, you must have the Report privilege enabled in your user account.
Information that is helpful to a user, such as when describing an alternate or simpler way to perform a task, is represented with a tip icon .	 You can also use the <b>CTRL+T</b> keyboard shortcut to show or hide thumbnail images.

## ISO 15223-1 Reference

Symbol	Symbol Name
	Medical device (MD)
	Manufacturer
	Date of Manufacture
	EU Authorized representative
	UK Authorized representative
	CE mark
	Catalogue number (REF)
	Serial number (SN)
	Unique Device Identifier (UDI)
	Consult instructions for use
	Caution
	Model Number

# RESIDUAL RISKS

Residual risks are communicated within this document as limitations, contraindications, precautions, cautions, or warnings.

## **Contraindications**

None.

## **Cautions**

The following cautions identify potential risks you should be aware of when using this device. Each caution is marked with the caution symbol ⚠.

- ⚠ Partial image loss due to software failures in DICOM load balancing leading to intermittent image spraying.
- ⚠ Failure to report image counts to central index leading to radiologist reading a study with missing images.
- ⚠ Displayed measurements of length, area, volume, and Standard Uptake Value are incorrect.
- ⚠ Federal law restricts this device to sale by or on the order of a physician.

## **Warnings**

None.

**Referring Physicians Use:**

Images for authorized referring physicians may not be of diagnosis quality and should not be used for diagnostic purposes.

**InteleConnect:**

Images in InteleConnect are intended for review only and are not appropriate for diagnostic purposes. Please use InteleViewer for diagnostic viewing.

**CD Burning and Nuage Patient Portal:**

Intelerad Clients remain responsible for collecting patient consents and accesses. Images on CD and on Nuage Patient Portal are intended for review only and are not appropriate for diagnostic purposes. Please use InteleViewer for diagnostic viewing.

# 1

## INTRODUCTION

This document contains DICOM conformance statements for applications comprising the IntelPACS Image Management System. These are scalable fault-tolerant systems for storing, archiving, and managing digital radiological information.

The IntelPACS Image Management System comprises a suite of applications running on a variety of servers that provide DICOM conformant services for both short and long term image storage and retrieval of digital image data. The applications use DICOM as the interface to the external world. An IntelPACS server accepts DICOM association requests for the purpose of storing images and for query and retrieval of images. It also initiates DICOM association requests for the purpose of sending images to an external application entity.

IntelPACS provide the following DICOM 3.0 functions:

- Verification of DICOM connectivity using the DICOM 3.0 Verification service class SCP.
- Short-term storage for images provided using the DICOM 3.0 Storage service class SCP.
- Storage commitment services provided using the DICOM 3.0 Storage Commitment SCP.
- Patient and Study scheduling information provided using the DICOM 3.0 Modality Worklist service class SCP. This function requires interface to Radiology Information System or use of IntelPACS Order Entry Tool.

- Long-term archive for images on magnetic tape supporting both manual systems and automated libraries (jukeboxes) using the DICOM 3.0 Storage service class SCP and archive management software.
- Ad-hoc Retrieval of data from the PACS using the DICOM Query/Retrieve service class SCP. The same interface provides access to both the short-term storage and long-term archive.
- Automatic routing of incoming images to destinations such as viewing workstations and archive servers using the DICOM 3.0 Storage service class SCU. The automatic routing is based on rules whose conditions are drawn from values in the DICOM 3.0 image header.
- RIS-triggered automatic prefetching of relevant studies based on radiology orders received from a RIS using the DICOM 3.0 Query/Retrieve and Storage service class SCU.
- Acquisition-triggered automatic prefetching of relevant studies to the same destination workstations as determined by the automatic routing process using the DICOM 3.0 Query/Retrieve and Storage service class SCUs. IntelPACS provides the ability to prefetch from any PACS that uses the DICOM 3.0 Query/Retrieve service class SCP and can authenticate both the IntelPACS SCU and the destination Application Entity.

# 2

## ABBREVIATIONS AND ACRONYMS

The following abbreviations and acronyms appear in this document:

- AE: Application Entity
- ANSI: American National Standards Institute
- API: Application Programming Interface
- DICOM: Digital Imaging and Communications in Medicine
- DIMSE-C: DICOM Message Service Element-Composite
- DIMSE-N: DICOM Message Service Element-Normalized
- IOD: Image Object Definition
- MPPS: Modality Performed Procedure Step
- PDU: Protocol Data Unit
- RIS: Radiology Information System
- SCP: Service Class Provider (server)
- SCU: Service Class User (client)
- SOP: Service Object Pair
- TCP/IP: Transmission Control Protocol/Internet Protocol
- UID: Unique Identifier

# 3

## IMPLEMENTATION MODEL

IntelPACS DICOM services are installed on several specialized servers providing Application Entities specific to the role of that server. Each IntelPACS server type provides a single Application Entity for all locally supported DICOM services. Multiple services may be combined on 'hybrid' servers in lower volume implementations, in which case the combined servers assume multiple Application Entities.

The following server types have been identified for the purposes of documenting application data flow: Modality Server, Master/Modality Server, Master Database/Web Server, Robotics Server, Archive Cache Server and RIS Interface Gateway.

### **Application Data Flow Diagram**

Application data flow diagrams are located with the functional definitions of each application entity.

### **Functional Definition of Application Entities**

Presented below are the functional definitions of DICOM service supported by Application Entities that comprise the IntelPACS Image Management System. Sections for services that have similar functional definitions on other Application Entities refer to those sections of this document to avoid repetition.

Application Entity functions can be combined on 'hybrid' servers in implementations with lower data volumes or which require less redundancy in their system design.

# Modality Server AE

## Verification

The verification service is provided to allow client applications to verify DICOM connectivity to IntelPACS servers. The server performs an association check for the calling Application Entity (client) to a control database based on the calling AE Title and TCP/IP address.

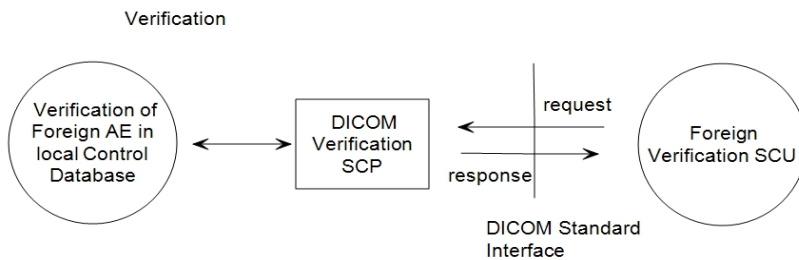

Depending on the results of the verification process, the server responds with either of the following:

- success
- rejected

Possible reasons for rejection are:

- Calling AE is unknown to the server.
- Called AE does not match the server AE.
- Calling AE does not match associated TCP/IP address for the client.

The verification control database is centrally managed and distributed to all server Application Entities. Therefore, successful verification with one server Application Entity implies successful verification to the entire PACS.

## Storage

Processing of a storage request begins with the same verification step using the same criteria described in section [“Verification” \(page 19\)](#). The server supports the A-Associate service to negotiate an association including supported SOP classes and Transfer Syntaxes for the storage request.

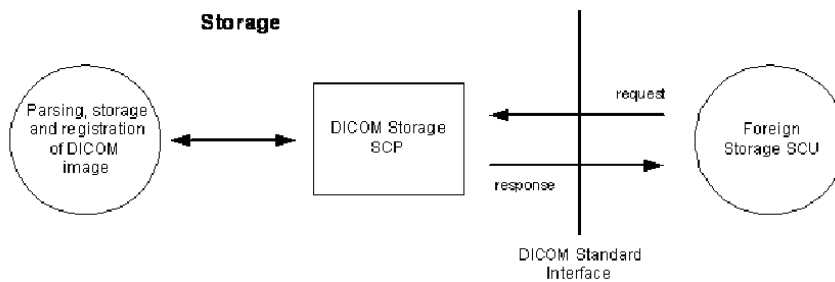

Possible reasons for rejection (other than verification issues) are:

- No supported SOP Classes in association.
- No Supported Transfer Syntaxes in association.
- Calling AE is not configured as a Storage SCU.

The Storage SCU configuration parameter is established when the calling AE is configured in IntelPACS through the IntelBrowser DICOM Configuration tool.

Once the (DIMSE)C-STORE process commences, images are stored temporarily and parsed for IOD conformance, in particular that all UIDs and required fields are present. Once successfully stored, the image is registered in the PACS and becomes available for DICOM Query/Retrieve services, archival, automatic routing and prefetching tasks. Duplicate images are 'silently' dropped by the server.

Possible reasons for failed storage are:

- Server failed to parse the image DICOM header.
- One or more required fields are missing from the DICOM header.
- One or more UID tags are related to other UIDs not present in this image.
- Local storage is full.
- The color space is not supported by the SCP AE and it is configured to reject this case.

## Storage Commitment

The server accepts a Storage Commitment request that includes a list of SOP Instance UIDs to be committed. The server checks each SOP Instance UID with the following requirements:

- The image is registered in the local image database.
- The image is physically located on the local storage medium.

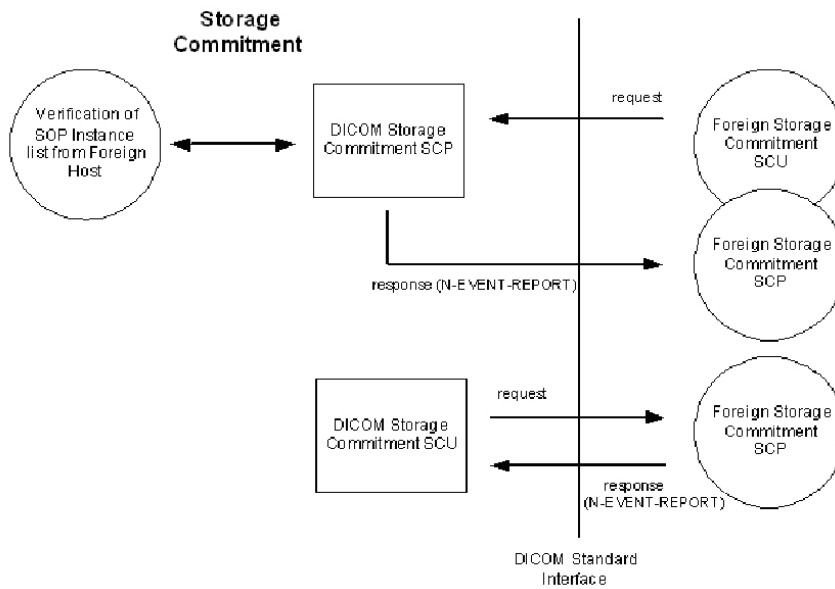

The server creates a Storage Commitment response and transmits this to the calling AE by establishing a separate association using the AE Title, TCP/IP address and Port specified in the control database.

The server issues Storage Commitment requests to Foreign Storage SCPs. On receipt of a failure N-ACTION response code, the server resends the SOP Instances to the Foreign storage SCP.

## Query/Retrieve

The server accepts C-FIND and C-MOVE requests from any validated AE that has the Allow Queries (C-FIND, C-MOVE) From This AE configuration option enabled. On this type of server, only data that is found in local storage and that meets the search criteria of the C-FIND request (for supported fields) is included in the C-FIND response.

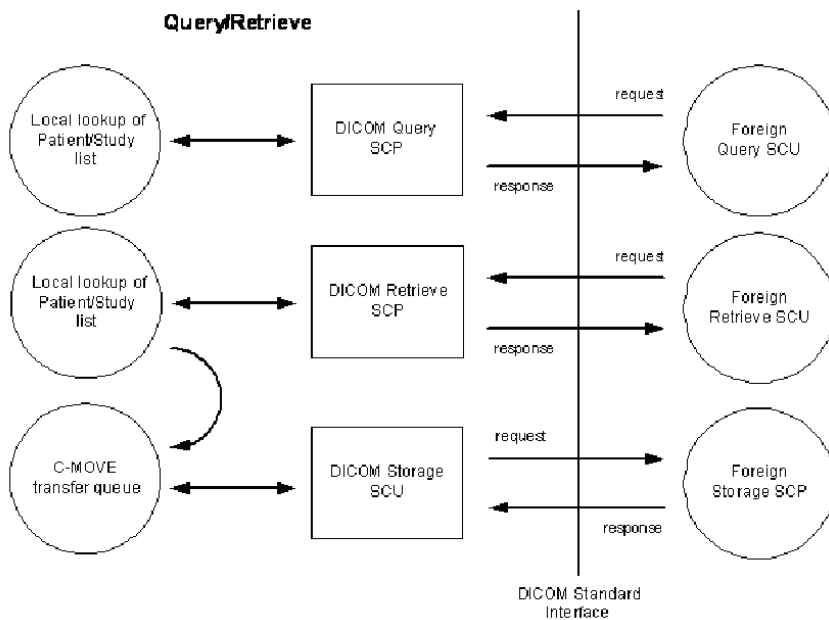

If the data for a C-MOVE request is found locally, the server then queues the data for asynchronous transfer to the destination AE. The server then returns an immediate response to the requester containing the following information:

- Successful sub-operations <# images>.
- Failed sub-operations <# images>.
- Remaining sub-operations <# images>.

Destination entities for C-MOVE requests must be configured as a Storage SCP.

## Automatic Routing

The server schedules each incoming image for automatic routing to destination Storage SCPs. Routing decisions are made following rule-sets and conditions based on fields in the image DICOM header. Once an image is scheduled for routing to one or more destinations, the server uses the Storage SCU service class to transmit the image.

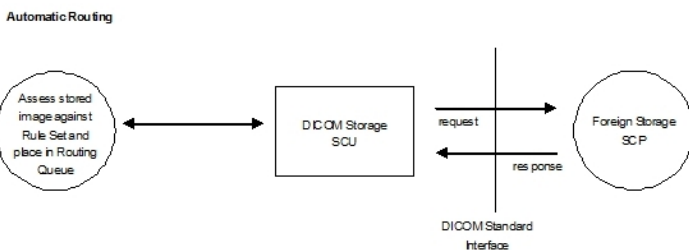

## Acquisition (DICOM) Prefetching

For each new study received, the server initiates rules-based prefetching from a designated PACS archive. The archive may be the same IntelPACS system or any other PACS that conforms to the DICOM 3.0 Query/Retrieve service class, accepts Query/Retrieve associations from the server AE and performs C-MOVE functions to the destination entities specified by the server.

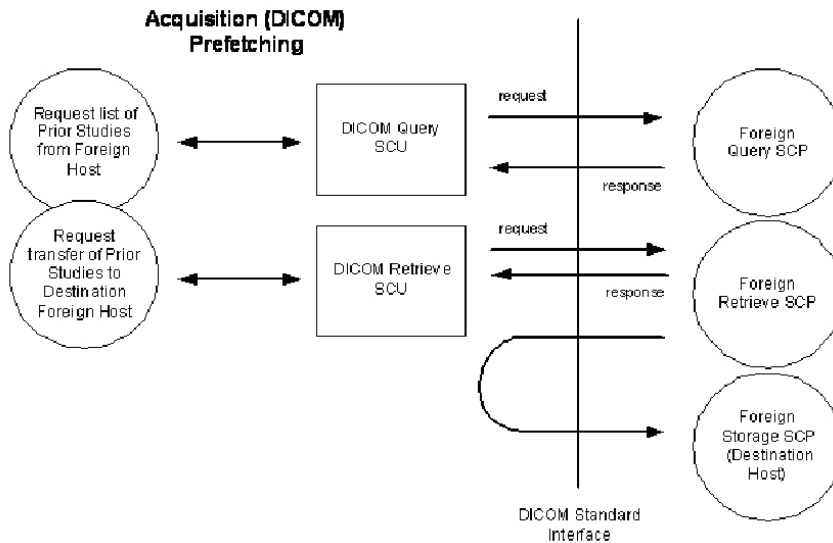

## Master/Modality Server AE

### Verification

Refer to section ["Verification" \(page 19\)](#).

### Storage

Refer to section ["Storage" \(page 19\)](#).

### Storage Commitment

Refer to section ["Storage Commitment" \(page 20\)](#).

### Query/Retrieve

The server accepts C-FIND and C-MOVE requests from any validated AE that has the Allow Queries (C-FIND, C-MOVE) From This AE configuration option enabled. On this type of server, data that is found on any server and that meets the search criteria of the C-FIND request (for supported fields) is included in the C-FIND response.

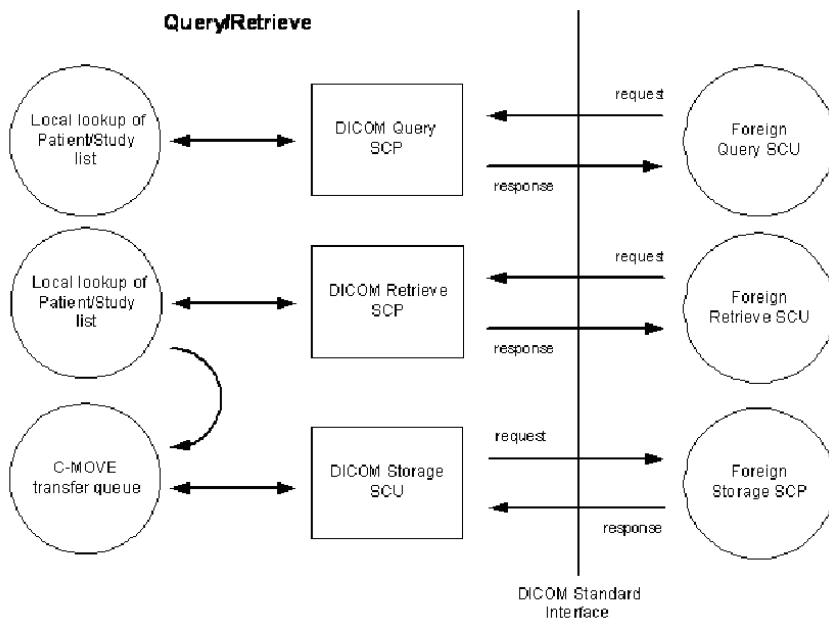

The server then queues the data for asynchronous transfer to the destination AE. The server then returns an immediate response to the requester containing the following information:

- Successful sub-operations <# images>.
- Failed sub-operations <# images>.
- Remaining sub-operations <# images>.

Destination entities for C-MOVE requests must be configured as a Storage SCP.

## Automatic Routing

The server schedules each incoming image for automatic routing to destination Storage SCPs. Routing decisions are made following rule-sets and conditions based on fields in the image DICOM header. Once an image is scheduled for routing to one or more destinations, the server uses the Storage SCU service class to transmit the image.

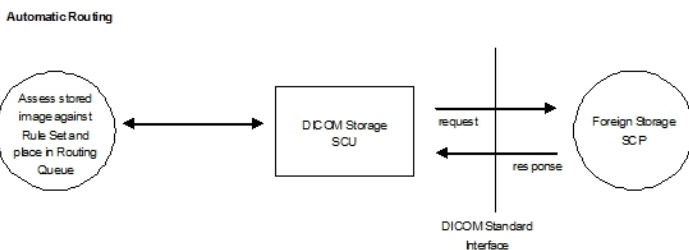

## Acquisition (DICOM) Prefetching

For each new study received, the server initiates rules-based prefetching from a designated PACS archive. The archive may be the same IntelPACS system or any other PACS that conforms to the DICOM 3.0 Query/Retrieve service class, accepts Query/Retrieve associations from the server AE and performs C-MOVE functions to the destination entities specified by the server.

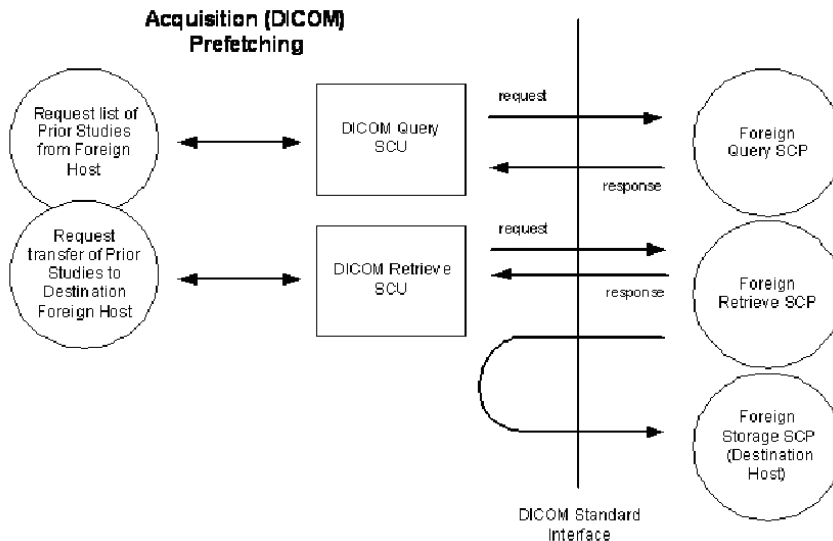

## Master Database/Web Server AE

### Verification

Refer to section ["Verification" \(page 19\)](#).

### Store-and-Forward

A Master Database/Web server provides a store-and-forward feature. Images that are sent to this type of server are stored temporarily in local storage but not registered in the PACS. The images are then forwarded to the appropriate short-term storage device using a DICOM C-STORE.

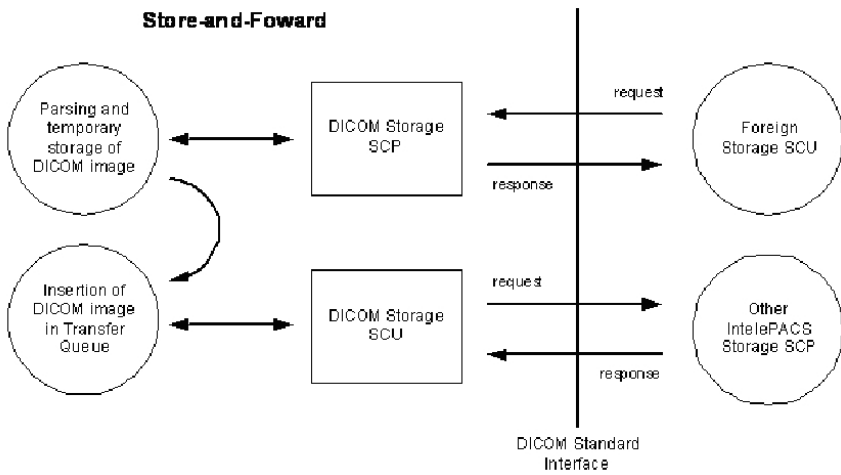

This feature will be deprecated in future releases of IntelePACS.

## Query/Retrieve

A Master Database/Web server does not provide local storage services to the PACS. All C-FIND requests initiate a search of the local Master Database that contains records of all studies stored in the PACS regardless of their current location. This provides a convenient way for the IntelePACS user to query the entire PACS without having to know where the data currently resides: short-term storage or long-term archive. It allows the PACS to have a limitless number of storage devices while providing a single DICOM-conformant access point.

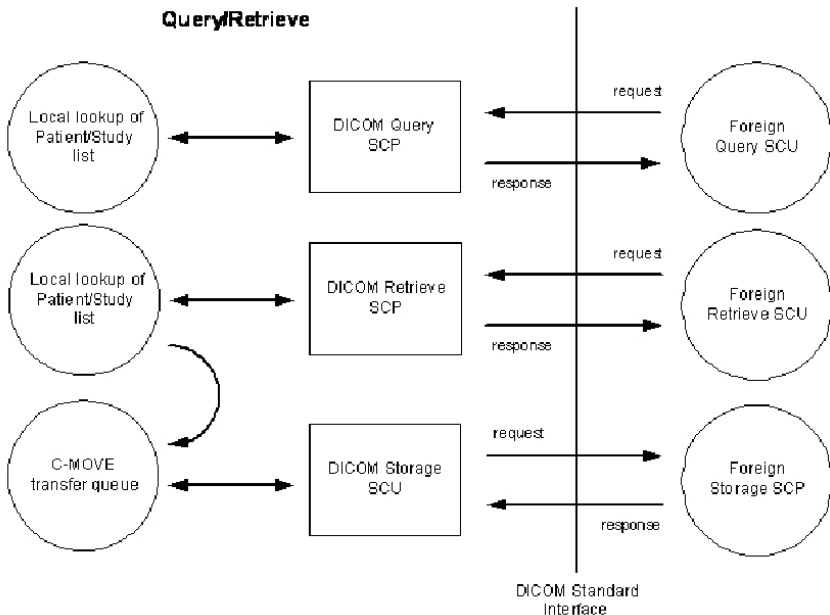

The server accepts C-FIND and C-MOVE requests from any validated AE that has the Allow Queries (C-FIND, C-MOVE) From This AE configuration option enabled. On this type of server, C-MOVE requests are broken into a list of series. For each series, the 'best' location is determined through one of a variety of configurable algorithms based on storage type, e.g. short-term, long-term, (ONLINE AVAILABILITY) and source location relative to destination (SITE AWARENESS).

If the data for a C-MOVE request is found on an available location in the PACS, the server initiates a C-MOVE request to the current 'best' location for the data. The server then returns an immediate response to the requester containing the following information:

- Successful sub-operations <# images>.
- Failed sub-operations <# images>.
- Remaining sub-operations <# images>.

Destination entities for C-MOVE requests must be configured as a Storage SCP.

## **Robotics Server AE**

### **Verification**

Refer to section ["Verification" \(page 19\)](#).

### **Query/Retrieve**

The Robotics Server AE supports only retrieve or C-MOVE services. Consequently, all data requests must go through a Master Database/Web Server. This type of server should never be queried by foreign Application Entities.

C-MOVE requests are added to a tape retrieval queue for processing by the retrieval applications.

## **Archive Cache Server AE**

### **Verification**

Refer to section ["Verification" \(page 19\)](#).

### **Storage**

Refer to section ["Storage" \(page 19\)](#).

## Query/Retrieve

Refer to section “[Query/Retrieve](#)” (page 21).

## RIS Interface Gateway AE

### Verification

Refer to section “[Verification](#)” (page 19).

## Modality Worklist

The RIS Interface Gateway (RIG) provides support for multiple Modality Worklists. Each Modality Worklist is accessible separately by supplying a different called AE Title to the RIG. The server obtains from the RIS orders in a state characterized as ‘Patient Arrived’ for a date range specified in the configuration of the RIG. A worklist database is built for each configured worklist entity and is available to any client using the Modality Worklist service class SCU.

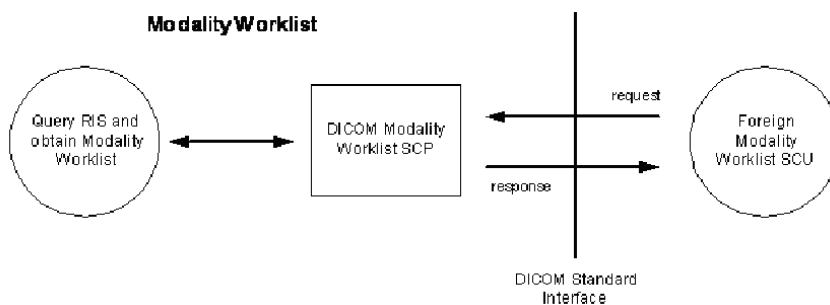

The server supports worklist queries by the following fields:

- Patient Name
- Patient ID (MRN)
- Accession Number
- Modality
- Scheduled Procedure Step Start Date
- Scheduled Procedure Step Start Time

The server optionally supplies a Study Instance UID and Station ID in the worklist response.

## Modality Performed Procedure Step

The Storage AE supports the MPPS SOP Class as an SCP, as shown in the following figure:

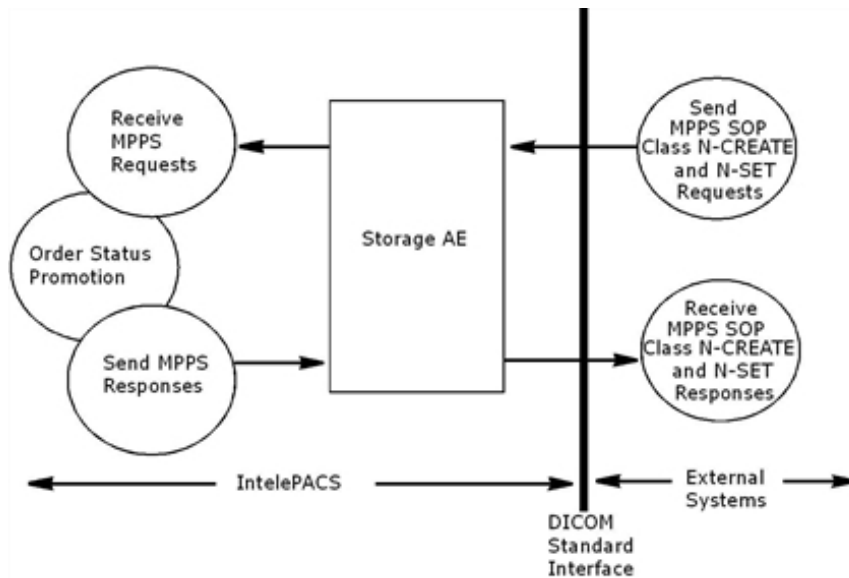

To receive MPPS, the AE Title needs to be configured. When the AE Title is configured, it changes the order status to one of the following codes:

- SC: Scheduled
- IP: Patient Arrived
- OC: Validated
- PC: Pending Completion
- HD: On Hold
- CM: Completed
- ZA: Dictated
- ZD: Transcribed
- ZE: Report Pending
- ZZ: Report Available
- CA: Cancelled
- ZY: Report Preliminary
- NG: Prior Order

# Sequencing of Real-World Activities

The server cannot determine when it has a complete study or what constitutes a complete study unless the client application uses the Storage Commitment service. If the server receives an image query while also receiving storage requests, the query response may not include all of the images that are in the study.

Automatic routing is performed on an image-by-image basis.

Acquisition prefetching is triggered by the arrival at the server of a new study (a study that is not already present in the short-term archive).

# 4

## INTELEPACS AE SPECIFICATIONS

The server processes are invoked once on a single machine. A single Application Entity title is assigned to an IntelPACS server for both SCP and SCU operations.

An IntelPACS server provides Standard Conformance to the following DICOM 3.0 SOP Classes:

SOP Classes Supported by an IntelPACS Server

SOP Class Name	SOP Class UID	SCU	SCP
Verification SOP Class	1.2.840.10008.1.1	No	Yes
Storage Commitment Push Model	1.2.840.10008.1.20.1	Yes	Yes
Modality Performed Procedure Step	1.2.840.10008.3.1.2.3.3	No	Yes
Presentation LUT	1.2.840.10008.5.1.1.23	Yes	Yes
Hardcopy Grayscale	1.2.840.10008.5.1.1.29	Yes	Yes
Hardcopy Color	1.2.840.10008.5.1.1.30	Yes	Yes
Computed Radiography Image Storage	1.2.840.10008.5.1.4.1.1.1	Yes	Yes
Digital X-Ray Image Storage – For Presentation	1.2.840.10008.5.1.4.1.1.1.1	Yes	Yes
Digital X-Ray Image Storage – For Processing	1.2.840.10008.5.1.4.1.1.1.1.1	Yes	Yes
Digital Mammography X-Ray	1.2.840.10008.5.1.4.1.1.1.2	Yes	Yes

SOP Class Name	SOP Class UID	SCU	SCP
Image Storage – For Presentation			
Digital Mammography X-Ray Image Storage – For Processing	1.2.840.10008.5.1.4.1.1.1.2.1	Yes	Yes
CT Image Storage	1.2.840.10008.5.1.4.1.1.2	Yes	Yes
Enhanced CT Image Storage (see note)	1.2.840.10008.5.1.4.1.1.2.1	Yes	Yes
Ultrasound Multi-frame Image Storage	1.2.840.10008.5.1.4.1.1.3	Retired	Retired
Ultrasound Multi-Frame Image Storage	1.2.840.10008.5.1.4.1.1.3.1	Yes	Yes
MR Image Storage	1.2.840.10008.5.1.4.1.1.4	Yes	Yes
Enhanced MR Color Image Storage	1.2.840.10008.5.1.4.1.1.4.3	Yes	Yes
Enhanced MR Image Storage	1.2.840.10008.5.1.4.1.1.4.1	Yes	Yes
Ultrasound Image Storage	1.2.840.10008.5.1.4.1.1.6.1	Yes	Yes
Secondary Capture Image Storage	1.2.840.10008.5.1.4.1.1.7	Yes	Yes
Multiframe Single Bit Secondary Capture	1.2.840.10008.5.1.4.1.1.7.1	Yes	Yes
Multi-frame Grayscale Word Secondary Capture Image Storage	1.2.840.10008.5.1.4.1.1.7.3	Yes	Yes
Multi-frame True Color Secondary Capture Image Storage	1.2.840.10008.5.1.4.1.1.7.4	Yes	Yes
*12-lead ECG Waveform Storage	1.2.840.10008.5.1.4.1.1.9.1.1	Yes	Yes
General ECG Waveform Storage	1.2.840.10008.5.1.4.1.1.9.1.2	Yes	Yes
Standalone Curve Storage	1.2.840.10008.5.1.4.1.1.9	Yes	Yes
Basic Voice Audio Waveform Storage	1.2.840.10008.5.1.4.1.1.9.4.1	Yes	Yes

SOP Class Name	SOP Class UID	SCU	SCP
Gray Softcopy Presentation State Storage SOP Class	1.2.840.10008.5.1.4.1.1.11.1	Yes	Yes
Color Softcopy Presentation State Storage SOP Class	1.2.840.10008.5.1.4.1.1.11.2	Yes	Yes
Gray Softcopy Presentation State Storage SOP Class	1.2.840.10008.5.1.4.1.1.11.1	Yes	Yes
X-Ray Angiographic Image Storage	1.2.840.10008.5.1.4.1.1.12.1	Yes	Yes
Enhanced XA	1.2.840.10008.5.1.4.1.1.12.1.1	Yes	Yes
X-Ray Radiofluoroscopic Image Storage	1.2.840.10008.5.1.4.1.1.12.2	Yes	Yes
Enhanced XRF	1.2.840.10008.5.1.4.1.1.12.2.1	Yes	Yes
XRay Angiographic Biplane	1.2.840.10008.5.1.4.1.1.12.3	Yes	Yes
Breast Tomosynthesis Image Storage	1.2.840.10008.5.1.4.1.1.13.1.3	Yes	Yes
**Breast Projection X-Ray Image Storage - For Presentation	1.2.840.10008.5.1.4.1.1.13.1.4	Yes	Yes
Nuclear Medicine Image Storage	1.2.840.10008.5.1.4.1.1.20	Yes	Yes
Raw Data Storage	1.2.840.10008.5.1.4.1.1.66	Yes	Yes
Spatial Registration Storage	1.2.840.10008.5.1.4.1.1.66.1	Yes	No
Deformable Spatial Registration Storage	1.2.840.10008.5.1.4.1.1.66.3	Yes	No
VL Endoscopic Image Storage	1.2.840.10008.5.1.4.1.1.77.1.1	Yes	Yes
Video Endoscopic Image Storage	1.2.840.10008.5.1.4.1.1.77.1.1.1	Yes	Yes
VL Microscopic Image Storage	1.2.840.10008.5.1.4.1.1.77.1.2	Yes	Yes
Video Microscopic	1.2.840.10008.5.1.4.1.1.77.1.2.1	Yes	Yes
VL Slide-Coordinates Microscopic Image Storage	1.2.840.10008.5.1.4.1.1.77.1.3	Yes	Yes
VL Photographic Image Storage	1.2.840.10008.5.1.4.1.1.77.1.4	Yes	Yes

SOP Class Name	SOP Class UID	SCU	SCP
Video Photographic	1.2.840.10008.5.1.4.1.1.77.1.4.1	Yes	Yes
Ophthalmic Photography 8-bit	1.2.840.10008.5.1.4.1.1.77.1.5.1	Yes	Yes
Ophthalmic Photography 16-bit	1.2.840.10008.5.1.4.1.1.77.1.5.2	Yes	Yes
Ophthalmic Tomography Image Storage	1.2.840.10008.5.1.4.1.1.77.1.5.4	Yes	Yes
Ophthalmic Tomography Storage	1.2.840.10008.5.1.4.1.1.77.1.5.5	Yes	Yes
Basic Text SR	1.2.840.10008.5.1.4.1.1.88.11	Yes	Yes
Enhanced SR	1.2.840.10008.5.1.4.1.1.88.22	Yes	Yes
Comprehensive SR	1.2.840.10008.5.1.4.1.1.88.33	Yes	Yes
Procedure Log Storage	1.2.840.10008.5.1.4.1.1.88.40	Yes	Yes
Mammography CAD SR	1.2.840.10008.5.1.4.1.1.88.50	Yes	Yes
Key Object Selection Document	1.2.840.10008.5.1.4.1.1.88.59	Yes	Yes
Chest CAD SR	1.2.840.10008.5.1.4.1.1.88.65	Yes	Yes
X-Ray Radiation Dose SR	1.2.840.10008.5.1.4.1.1.88.67	Yes	Yes
OB-GYN Ultrasound Procedure Reports	1.2.840.10008.5.1.4.1.1.88.5000	Yes	Yes
Vascular Ultrasound SR	1.2.840.10008.5.1.4.1.1.88.5100	Yes	Yes
Encapsulated PDF Storage	1.2.840.10008.5.1.4.1.1.104.1	Yes	Yes
Positron Emission Tomography Image Storage	1.2.840.10008.5.1.4.1.1.128	Yes	Yes
Standalone PET Curve Storage	1.2.840.10008.5.1.4.1.1.129	Yes	Yes
Enhanced PET	1.2.840.10008.5.1.4.1.1.130	Yes	Yes
RT Image Storage	1.2.840.10008.5.1.4.1.1.481.1	Yes	Yes
RT Dose Storage	1.2.840.10008.5.1.4.1.1.481.2	Yes	Yes
RT Structure Storage	1.2.840.10008.5.1.4.1.1.481.3	Yes	Yes
RT Beams Treatment Record	1.2.840.10008.5.1.4.1.1.481.4	Yes	Yes
RT Plan Storage	1.2.840.10008.5.1.4.1.1.481.5	Yes	Yes
Patient Root Query/ Retrieve	1.2.840.10008.5.1.4.1.2.1.1	No	Yes

SOP Class Name	SOP Class UID	SCU	SCP
Info Model –FIND			
Patient Root Query/ Retrieve Info Model –MOVE	1.2.840.10008.5.1.4.1.2.1.2	No	Yes
Study Root Query/ Retrieve Info Model –FIND	1.2.840.10008.5.1.4.1.2.2.1	Yes	Yes
Study Root Query/ Retrieve Info Model –MOVE	1.2.840.10008.5.1.4.1.2.2.2	Yes	Yes
Patient/Study Only Query/Retrieve Information Model – FIND	1.2.840.10008.5.1.4.1.2.3.1	No	Yes
Patient/Study Only Query/ Retrieve Information Model – MOVE	1.2.840.10008.5.1.4.1.2.3.3	No	Yes
Modality Worklist Information Model—FIND	1.2.840.10008.5.1.4.31	No	Yes
* - This indicates SOP Class Name is available for IntelPACS version 4.14.1 and later.			
** - This indicates SOP Class Name is available for IntelPACS version 5.1.1 and later.			

 For related information on the types of images and modalities that can be displayed by IntelPACS, see the *IntelViewer DICOM Conformance Statement*

## Association Establishment Policies

### General

The server attempts to initiate associations in response to C-MOVE requests from other Application Entities. The server only initiates associations in response to valid C-MOVE requests for images that are known to the server (stored in its database).

The maximum PDU size, which can be transmitted and received by the server, is fixed at 16KB.

### Number of Associations

The number of simultaneous associations (normally 25) that will be accepted by an IntelPACS server is established during a configuration step. The server spawns a new

process for each association request that it receives. There is no inherent limitation on the total number of simultaneous associations except for the limits imposed by the operating system and hardware on which the server is running. However, although an IntelPACS server allows it, Intelrad recommends avoiding more than one simultaneous association per Application Entity.

## **Asynchronous Nature**

IntelPACS servers support asynchronous operations including C-MOVE operations.

## **Implementation Identifying Information**

IntelPACS servers provide an implementation class UID of 1.2.840.114202.5.3 of which 1.2.840.114202 is the ANSI registered Intelrad Medical Systems UID root.

The server provides an implementation version name of IMSM-m-r-Pp where M-m-r-Pp is the IntelPACS version.

## **Association Initiation Policy**

The server attempts to initiate one association in response to each C-MOVE command it receives from an external node. The server attempts a single type of association request. The server supports the C-MOVE SOP classes listed in Table 5. In response to a move request, the server supports the Storage SOP classes that are listed in Table 1.

The server attempts to initiate one C-FIND request for each DICOM prefetching event scheduled by C-STORE activities. The server then attempts one C-MOVE request for each matching prior study obtained in the previous step for each destination Application Entity.

## **Real-World Activity—Move Request From an External Node**

### **Associated Real-World Activity—Move Request From an External Node**

The associated Real-World activity is a C-MOVE request from an external application. If an application successfully establishes an association with an IntelPACS server and makes a valid C-MOVE request that identifies one or more images known to the server, the server adds a C-MOVE request to a move request queue that is processed

asynchronously. The server performs only one move operation even if there are multiple requests for the same data.

On a Master Database or Web Server, C-MOVE requests are processed from a global view, where the server at the "best" location delivers the images to the external application.

## Proposed Presentation Contexts

In response to a C-MOVE request, the server builds a complete list of series to be moved. The list includes the SOP class of each series found. The association request will have a single presentation context, which contains the abstract syntax that identifies the image class as found in the series list. The presentation contexts in the following table require no extended negotiation.

Proposed Presentation Contexts for an IntelPACS Server

<b>Abstract Syntax</b>	<b>Transfer Syntax</b>	<b>Role</b>	<b>Abstract Syntax</b>	<b>Transfer Syntax</b>
<b>Name</b>	<b>UID</b>	<b>Name</b>	<b>UID</b>	<b>Name</b>
See note	See note	Implicit VR Little Endian Transfer Syntax	1.2.840.10008.1.2	SCU
See note	See note	Explicit VR Little Endian Transfer Syntax	1.2.840.10008.1.2.1	SCU
See note	See note	JPEG Baseline (Process 1)	1.2.840.10008.1.2.4.50	SCU
See note	See note	JPEG Extended (Process 2, 4)	1.2.840.10008.1.2.4.51	SCU
See note	See note	JPEG Lossless, Non-Hierarchical, First-Order	1.2.840.10008.1.2.4.70	SCU

Abstract Syntax	Transfer Syntax	Role	Abstract Syntax	Transfer Syntax
Name	UID	Name	UID	Name
		Prediction (Process 14 [Selection Value 1])		
See note	See note	JPEG 2000 Lossless Only	1.2.840.10008.1.2.4.90	SCU
See note	See note	MPEG2 Main Profile @ High Level	1.2.840.10008.1.2.4.10 1	SCU
See note	See note	MPEG2 Main Profile @ Main Level	1.2.840.10008.1.2.4.10 0	SCU
See note	See note	RLE Lossless	1.2.840.10008.1.2.5	SCU
Modality Performed Procedure Step SOP Class	1.2.840.10008.3.1.2.3. 3	Implicit VR Little Endian Transfer Syntax	1.2.840.10008.1.2	SCP

- ☰ The Abstract Syntax corresponds to the value found in the database maintained by each server. More than one presentation context can be offered, each with a different abstract syntax.
- ☰ If the server stored the images in Implicit VR Little Endian Transfer Syntax, some images may have been stored by the server with private elements whose encoding scheme is unknown by the server. These elements will be transmitted by the server exactly as they were received and they are unaltered upon transmission.

☰ If the images are stored in JPEG Baseline or JPEG Extended, they will be transmitted by the server in the transfer syntax they are stored. There is no conversion from Implicit VR Little Endian or Explicit VR Little Endian images to JPEG Baseline or JPEG Extended.

### **SOP Specific Conformance—Move Request from an External Node**

All C-STORE operations are in the context of a C-MOVE request from an external node. The IntelPACS server sends one C-MOVE response message for each attempted queue insertion.

The server does not attempt any extended negotiation. The server does not delete any elements from the files it transfers. Therefore the set of optional elements depends entirely on the contents of the files which were originally stored on the server.

The server may optionally change Photometric Interpretation for out-bound objects to accommodate those Application Entities that cannot support specific interpretations. The server may optionally re-map specific elements to accommodate requirements of the Storage SCP. This is established during a configuration step.

The server will attempt a JPEG 2000 Lossless Only transfer syntax to accommodate requirements of the Storage SCP. This is established during a configuration step.

The server will attempt a JPEG Baseline (Process 1) or JPEG Extended (Process 2,4) if the stored SOP is in this transfer syntax.

In the event that the server receives an unsuccessful C-STORE response, the server continues attempts to transfer the image set until either all images have been successfully transmitted or the request is timed out. In the event that the transfer syntax is JPEG 2000 Lossless Only or JPEG Lossless, Non-Hierarchical, First-Order Prediction and the server receives an unsuccessful C-STORE response, the server falls back to negotiating an Implicit VR Little Endian or Explicit VR Little Endian transfer syntax for the remainder of the series.

In the event that the transfer syntax is JPEG Baseline (Process 1) or JPEG Extended (Process 2,4) and the server receives an unsuccessful C-STORE response, the server does not fall back to negotiating an Implicit VR Little Endian or Explicit VR Little Endian transfer syntax.

If the data is stored in Implicit VR Little Endian or Explicit VR Little Endian, no conversion is performed to JPEG Baseline (Process 1) or JPEG Extended (Process 2,4).

If a destination is considered insecure (determined during a configuration step) the server removes the Patient Name from any out-bound objects before transferring them.

## Real-World Activity—DICOM Prefetching

### Associated Real-World Activity—DICOM Prefetching

The IntelPACS server performs Query/Retrieve operations to PACS archives to retrieve prior studies to diagnostic workstations.

When a new study is received by a server, a list of prior studies is fetched from the PACS archive using a DICOM C-FIND using the Study Root Information Model. For each prior in this list, a DICOM C-MOVE request is initiated to the PACS archive for each destination that it has been determined (through rules-based logic) should receive the prior study.

### Proposed Presentation Contexts

Refer to section [1](#).

### SOP Specific Conformance—DICOM Prefetching

The following table lists elements in the C-FIND request for DICOM Prefetching.

Elements in DICOM Prefetching  
Query

Description	Tag
Patient Name	0010 0010
Patient ID	0010 0020
Study Date	0008 0020
Accession Number	0008 0050
Modality	0008 0060
Study Description	0008 1030

## Real-World Activity—DICOM Modality Performed Procedure Step

### Associated Real-World Activity—DICOM Modality Performed Procedure Step

The IntelPACS software, acting in the role of SCP, can receive an MMPS status MPPS\_COMPLETED, and promote the HL7 order status to one of the following codes:

- SC: Scheduled
- IP: Patient Arrived
- OC: Validated
- PC: Pending Completion
- HD: On Hold
- CM: Completed
- ZA: Dictated
- ZD: Transcribed
- ZE: Report Pending
- ZZ: Report Available
- CA: Cancelled
- ZY: Report Preliminary
- NG: Prior Order

### Proposed Presentation Contexts

Refer to section [1](#).

## Association Acceptance Policy

The IntelPACS server accepts associations for the purpose of storing images in its database, for the purpose of performing Query/Retrieve operations on the images that have been previously stored, for the purpose of providing Storage Commitment services for stored images or for the purpose of providing Modality Worklist services.

The server only accepts association requests from applications that are defined during configuration. In addition, the server only stores images sent by nodes that have been enabled by a configuration step.

# Real-World Activity—Storage

## Associated Real-World Activity—Storage

The IntelPACS server accepts associations from nodes that wish to store images using the C-STORE command.

The associated Real-World activity associated with the C-STORE operation is the storage of the image on the disk of the system upon which the server is running. Images are stored by writing the data set of the C-STORE command directly to disk. Images headers are modified under the following circumstances:

- The server is performing storage of teaching files. In this case, the Patient Name field is replaced by the text BLANK^NAME.
- The server detects a violation of the DICOM standard in a unique identifier, for example a leading zero in a multi-digit element of a Study, Series or SOP Instance UID. In this case, the server attempts to repair the UID while preserving uniqueness.
- The server retrieves RIS information for the current study during a validation step and that information conflicts with demographics present in the images. In this case, the server substitutes the RIS values into the DICOM elements.
- The server is configured to re-map specific DICOM header fields to other fields.
- The server is configured to write the calling Application Entity Description into the element Institutional Department Name (0008 1040).
- The server is configured to write its AE Title, the AE Title and Organization of the calling Application Entity (SCU), MD5Sum, Histogram, Largest and Smallest Pixel Value, into private tags.
- The server is configured to convert YBR (specifically, YBR FULL and YBR FULL 422) images to RGB.

After the image is stored to disk, the server updates an image database with patient, study, series and image information. This information is used by the server for Query/Retrieve operations.

Image database patient, study, series and location information are transferred to one or more central master databases located on Master Database/Web Servers. Series location information consist primarily of the Series Instance UID for the image set, the Application Entity Title of the C-STORE SCP (the server) and the number of images in the series.

The server issues a failure status if it is unable to store the image on disk, if the image does not conform to the IOD of the SOP class under which it was transmitted, or if the server is not able to successfully update its image database.

Duplicate images, those with a SOP Instance UID already stored on the server are accepted and silently ignored. Images must be explicitly deleted from the server before they can be replaced with altered copies.

## Presentation Context Table

Any of the Presentation Contexts shown in the following table are acceptable to the server for receiving images. These Presentation Contexts are for the role of SCP and require no extended negotiation.

Acceptable Presentation Contexts for an IntelPACS Server—Storage

Abstract Syntax Name	Abstract Syntax UID	Transfer Syntax Name	Transfer Syntax UID
Computed Radiography Image Storage	1.2.840.10008.5.1.4.1.1.1	Implicit VR Little Endian *See note	1.2.840.10008.1.2
		Explicit VR Little Endian *See note	1.2.840.10008.1.2.1
		Explicit VR Big Endian *See note	1.2.840.10008.1.2.2
		JPEG 2000 Image Compression *See note	1.2.840.10008.1.2.4.91
CT Image Storage	1.2.840.10008.5.1.4.1.1.2	Implicit VR Little Endian *See note	1.2.840.10008.1.2
		Explicit VR Little Endian *See note	1.2.840.10008.1.2.1
		Explicit VR Big Endian	1.2.840.10008.1.2.2

Abstract Syntax Name	Abstract Syntax UID	Transfer Syntax Name	Transfer Syntax UID
		*See note	
		JPEG 2000 Image Compression *See note	1.2.840.10008.1.2.4.91
Enhanced CT Image Storage	1.2.840.10008.5.1.4.1.1.2.1	Implicit VR Little Endian *See note	1.2.840.10008.1.2
		Explicit VR Little Endian *See note	1.2.840.10008.1.2.1
		Explicit VR Big Endian *See note	1.2.840.10008.1.2.2
		JPEG 2000 Image Compression *See note	1.2.840.10008.1.2.4.91
Ultrasound Multi-Frame Image Storage	1.2.840.10008.5.1.4.1.1.3.1	Implicit VR Little Endian *See note	1.2.840.10008.1.2
		Explicit VR Little Endian *See note	1.2.840.10008.1.2.1
		Explicit VR Big Endian *See note	1.2.840.10008.1.2.2
		JPEG 2000 Image Compression *See note	1.2.840.10008.1.2.4.91
MR Image Storage	1.2.840.10008.5.1.4.1.1.4	Implicit VR Little Endian *See note	1.2.840.10008.1.2

Abstract Syntax Name	Abstract Syntax UID	Transfer Syntax Name	Transfer Syntax UID
		Explicit VR Little Endian *See note	1.2.840.10008.1.2.1
		Explicit VR Big Endian *See note	1.2.840.10008.1.2.2
		JPEG 2000 Image Compression *See note	1.2.840.10008.1.2.4.91
Nuclear Medicine Image Storage	1.2.840.10008.5.1.4.1.1.20	Implicit VR Little Endian *See note	1.2.840.10008.1.2
		Explicit VR Little Endian *See note	1.2.840.10008.1.2.1
		Explicit VR Big Endian *See note	1.2.840.10008.1.2.2
		JPEG 2000 Image Compression *See note	1.2.840.10008.1.2.4.91
Ultrasound Image Storage	1.2.840.10008.5.1.4.1.1.6.1	Implicit VR Little Endian *See note	1.2.840.10008.1.2
		Explicit VR Little Endian *See note	1.2.840.10008.1.2.1
		Explicit VR Big Endian *See note	1.2.840.10008.1.2.2
		JPEG 2000 Image	1.2.840.10008.1.2.4.91

<b>Abstract Syntax Name</b>	<b>Abstract Syntax UID</b>	<b>Transfer Syntax Name</b>	<b>Transfer Syntax UID</b>
		Compression *See note	
Secondary Capture Image Storage	1.2.840.10008.5.1.4.1.1.7	Implicit VR Little Endian *See note	1.2.840.10008.1.2
		Explicit VR Little Endian *See note	1.2.840.10008.1.2.1
		Explicit VR Big Endian *See note	1.2.840.10008.1.2.2
		JPEG 2000 Image Compression *See note	1.2.840.10008.1.2.4.91
Multi-frame Grayscale Word Secondary Capture Image Storage	1.2.840.10008.5.1.4.1.1.7.3	Implicit VR Little Endian *See note	1.2.840.10008.1.2
		Explicit VR Little Endian *See note	1.2.840.10008.1.2.1
		Explicit VR Big Endian *See note	1.2.840.10008.1.2.2
		JPEG 2000 Image Compression *See note	1.2.840.10008.1.2.4.91
Multi-frame True Color Secondary Capture Image Storage	1.2.840.10008.5.1.4.1.1.7.4	Implicit VR Little Endian *See note	1.2.840.10008.1.2

Abstract Syntax Name	Abstract Syntax UID	Transfer Syntax Name	Transfer Syntax UID
		Explicit VR Little Endian *See note	1.2.840.10008.1.2.1
		Explicit VR Big Endian *See note	1.2.840.10008.1.2.2
		JPEG 2000 Image Compression *See note	1.2.840.10008.1.2.4.91
Stand-alone Overlay Storage	1.2.840.10008.5.1.4.1.1.8	Implicit VR Little Endian *See note	1.2.840.10008.1.2
		Explicit VR Little Endian *See note	1.2.840.10008.1.2.1
		Explicit VR Big Endian *See note	1.2.840.10008.1.2.2
		JPEG 2000 Image Compression *See note	1.2.840.10008.1.2.4.91
Stand-alone Curve Storage	1.2.840.10008.5.1.4.1.1.9	Implicit VR Little Endian *See note	1.2.840.10008.1.2
		Explicit VR Little Endian *See note	1.2.840.10008.1.2.1
Waveform WV Modality Storage	1.2.840.10008.5.1.4.1.1.9.1	Implicit VR Little Endian *See note	1.2.840.10008.1.2

Abstract Syntax Name	Abstract Syntax UID	Transfer Syntax Name	Transfer Syntax UID
		Explicit VR Little Endian *See note	1.2.840.10008.1.2.1
		Explicit VR Big Endian *See note	1.2.840.10008.1.2.2
		JPEG 2000 Image Compression *See note	1.2.840.10008.1.2.4.91
X-Ray Angiographic Image Storage	1.2.840.10008.5.1.4.1.1.12.1	Implicit VR Little Endian *See note	1.2.840.10008.1.2
		Explicit VR Little Endian *See note	1.2.840.10008.1.2.1
		Explicit VR Big Endian *See note	1.2.840.10008.1.2.2
		JPEG 2000 Image Compression *See note	1.2.840.10008.1.2.4.91
Positron Emission Tomography Image Storage	1.2.840.10008.5.1.4.1.1.128	Implicit VR Little Endian *See note	1.2.840.10008.1.2
		Explicit VR Little Endian *See note	1.2.840.10008.1.2.1
		Explicit VR Big Endian *See note	1.2.840.10008.1.2.2
		JPEG 2000	1.2.840.10008.1.2.4.

Abstract Syntax Name	Abstract Syntax UID	Transfer Syntax Name	Transfer Syntax UID
		Image Compression *See note	91
Standalone PET Curve Storage	1.2.840.10008.5.1.4.1.1.129	Implicit VR Little Endian *See note	1.2.840.10008.1.2
		Explicit VR Little Endian *See note	1.2.840.10008.1.2.1
		Explicit VR Big Endian *See note	1.2.840.10008.1.2.2
		JPEG 2000 Image Compression *See note	1.2.840.10008.1.2.4.91
RT Image Storage	1.2.840.10008.5.1.4.1.1.481.1	Implicit VR Little Endian *See note	1.2.840.10008.1.2
		Explicit VR Little Endian *See note	1.2.840.10008.1.2.1
		Explicit VR Big Endian *See note	1.2.840.10008.1.2.2
		JPEG 2000 Image Compression *See note	1.2.840.10008.1.2.4.91
RT Dose Storage	1.2.840.10008.5.1.4.1.1.481.2	Implicit VR Little Endian *See note	1.2.840.10008.1.2
		Explicit VR Little Endian	1.2.840.10008.1.2.1

Abstract Syntax Name	Abstract Syntax UID	Transfer Syntax Name	Transfer Syntax UID
		*See note Explicit VR Big Endian *See note	1.2.840.10008.1.2.2
		JPEG 2000 Image Compression *See note	1.2.840.10008.1.2.4.91
RT Structure Storage	1.2.840.10008.5.1.4.1.1.481.3	Implicit VR Little Endian *See note	1.2.840.10008.1.2
		Explicit VR Little Endian *See note	1.2.840.10008.1.2.1
		Explicit VR Big Endian *See note	1.2.840.10008.1.2.2
		JPEG 2000 Image Compression *See note	1.2.840.10008.1.2.4.91
RT Plan Storage	1.2.840.10008.5.1.4.1.1.481.5	Implicit VR Little Endian *See note	1.2.840.10008.1.2
		Explicit VR Little Endian *See note	1.2.840.10008.1.2.1
		Explicit VR Big Endian *See note	1.2.840.10008.1.2.2
		JPEG 2000 Image Compression *See note	1.2.840.10008.1.2.4.91

<b>Abstract Syntax Name</b>	<b>Abstract Syntax UID</b>	<b>Transfer Syntax Name</b>	<b>Transfer Syntax UID</b>
VL Endoscopic Image Storage	1.2.840.10008.5.1.4.1.1.77.1.1	Implicit VR Little Endian *See note	1.2.840.10008.1.2
		Explicit VR Little Endian *See note	1.2.840.10008.1.2.1
		Explicit VR Big Endian *See note	1.2.840.10008.1.2.2
		JPEG 2000 Image Compression *See note	1.2.840.10008.1.2.4.91
VL Microscopic Image Storage	1.2.840.10008.5.1.4.1.1.77.1.2	Implicit VR Little Endian *See note	1.2.840.10008.1.2
		Explicit VR Little Endian *See note	1.2.840.10008.1.2.1
		Explicit VR Big Endian *See note	1.2.840.10008.1.2.2
		JPEG 2000 Image Compression *See note	1.2.840.10008.1.2.4.91
VL Slide-Coordinates Microscopic Image Storage	1.2.840.10008.5.1.4.1.1.77.1.3	Implicit VR Little Endian *See note	1.2.840.10008.1.2
		Explicit VR Little Endian *See note	1.2.840.10008.1.2.1
		Explicit VR Big Endian	1.2.840.10008.1.2.2

Abstract Syntax Name	Abstract Syntax UID	Transfer Syntax Name	Transfer Syntax UID
		*See note	
		JPEG 2000 Image Compression *See note	1.2.840.10008.1.2.4.91
VL Photographic Image Storage	1.2.840.10008.5.1.4.1.1.77.1.4	Implicit VR Little Endian *See note	1.2.840.10008.1.2
		Explicit VR Little Endian *See note	1.2.840.10008.1.2.1
		Explicit VR Big Endian *See note	1.2.840.10008.1.2.2
		JPEG 2000 Image Compression *See note	1.2.840.10008.1.2.4.91
Patient Root Query/Retrieve Info Model – FIND	1.2.840.10008.5.1.4.1.2.1.1	Implicit VR Little Endian	1.2.840.10008.1.2
		Explicit VR Big Endian *See note	1.2.840.10008.1.2.2
		JPEG 2000 Image Compression *See note	1.2.840.10008.1.2.4.91
Patient Root Query/Retrieve Info Model – MOVE	1.2.840.10008.5.1.4.1.2.1.2	Implicit VR Little Endian	1.2.840.10008.1.2
		Explicit VR Big Endian *See note	1.2.840.10008.1.2.2
		JPEG 2000	1.2.840.10008.1.2.4.

Abstract Syntax Name	Abstract Syntax UID	Transfer Syntax Name	Transfer Syntax UID
		Image Compression *See note	91
Study Root Query/Retrieve Info Model – FIND	1.2.840.10008.5.1.4.1.2.2.1	Implicit VR Little Endian	1.2.840.10008.1.2
		Explicit VR Big Endian *See note	1.2.840.10008.1.2.2
		JPEG 2000 Image Compression *See note	1.2.840.10008.1.2.4.91
Study Root Query/Retrieve Info Model – MOVE	1.2.840.10008.5.1.4.1.2.2.2	Implicit VR Little Endian	1.2.840.10008.1.2
		Explicit VR Big Endian *See note	1.2.840.10008.1.2.2
		JPEG 2000 Image Compression *See note	1.2.840.10008.1.2.4.91
Storage Commitment Push Model	1.2.840.10008.1.20.1	Implicit VR Little Endian	1.2.840.10008.1.2
		Explicit VR Big Endian *See note	1.2.840.10008.1.2.2
		JPEG 2000 Image Compression *See note	1.2.840.10008.1.2.4.91
Modality Worklist Information Model—FIND	1.2.840.10008.5.1.4.31	Implicit VR Little Endian	1.2.840.10008.1.2

Abstract Syntax Name	Abstract Syntax UID	Transfer Syntax Name	Transfer Syntax UID
		Explicit VR Big Endian *See note	1.2.840.10008.1.2.2
		JPEG 2000 Image Compression *See note	1.2.840.10008.1.2.4.91
Key Object Selection	1.2.840.10008.5.1.4.1.1.88.59	Implicit VR Little Endian *See note	1.2.840.10008.1.2
		Explicit VR Little Endian *See note	1.2.840.10008.1.2.1
		Explicit VR Big Endian *See note	1.2.840.10008.1.2.2
		JPEG 2000 Image Compression *See note	1.2.840.10008.1.2.4.91
		Implicit VR Little Endian *See note	1.2.840.10008.1.2
Digital X-Ray Image Storage – For Presentation	1.2.840.10008.5.1.4.1.1.1.1	Explicit VR Little Endian *See note	1.2.840.10008.1.2.1
		Explicit VR Big Endian *See note	1.2.840.10008.1.2.2
		Explicit VR Little Endian *See note	1.2.840.10008.1.2.1
		JPEG 2000 Image Compression *See note	1.2.840.10008.1.2.4.91

<b>Abstract Syntax Name</b>	<b>Abstract Syntax UID</b>	<b>Transfer Syntax Name</b>	<b>Transfer Syntax UID</b>
Digital X-Ray Image Storage – For Processing	1.2.840.10008.5.1.4.1.1.1.1.1	Implicit VR Little Endian *See note	1.2.840.10008.1.2
		Explicit VR Little Endian *See note	1.2.840.10008.1.2.1
		Explicit VR Big Endian *See note	1.2.840.10008.1.2.2
		JPEG 2000 Image Compression *See note	1.2.840.10008.1.2.4.91
Digital Mammography X-Ray Image Storage – For Presentation	1.2.840.10008.5.1.4.1.1.1.2	Implicit VR Little Endian *See note	1.2.840.10008.1.2
		Explicit VR Little Endian *See note	1.2.840.10008.1.2.1
		Explicit VR Big Endian *See note	1.2.840.10008.1.2.2
		JPEG 2000 Image Compression *See note	1.2.840.10008.1.2.4.91
Digital Mammography X-Ray Image Storage – For Processing	1.2.840.10008.5.1.4.1.1.1.2.1	Implicit VR Little Endian *See note	1.2.840.10008.1.2
		Explicit VR Little Endian *See note	1.2.840.10008.1.2.1
		Explicit VR Big Endian	1.2.840.10008.1.2.2

Abstract Syntax Name	Abstract Syntax UID	Transfer Syntax Name	Transfer Syntax UID
		*See note	
		JPEG 2000 Image Compression *See note	1.2.840.10008.1.2.4.91
Ultrasound Multi-frame Image Storage (Retired)	1.2.840.10008.5.1.4.1.1.3	Implicit VR Little Endian *See note	1.2.840.10008.1.2
		Explicit VR Little Endian *See note	1.2.840.10008.1.2.1
		Explicit VR Big Endian *See note	1.2.840.10008.1.2.2
		JPEG 2000 Image Compression *See note	1.2.840.10008.1.2.4.91
X-Ray Radiofluoroscopic Image Storage	1.2.840.10008.5.1.4.1.1.12.2	Implicit VR Little Endian *See note	1.2.840.10008.1.2
		Explicit VR Little Endian *See note	1.2.840.10008.1.2.1
		Explicit VR Big Endian *See note	1.2.840.10008.1.2.2
		JPEG 2000 Image Compression *See note	1.2.840.10008.1.2.4.91
Gray Softcopy Pres State Storage	1.2.840.10008.5.1.4.1.1.11.1	Implicit VR Little Endian *See note	1.2.840.10008.1.2

Abstract Syntax Name	Abstract Syntax UID	Transfer Syntax Name	Transfer Syntax UID
		Explicit VR Little Endian *See note	1.2.840.10008.1.2.1
		Explicit VR Big Endian *See note	1.2.840.10008.1.2.2
		JPEG 2000 Image Compression *See note	1.2.840.10008.1.2.4.91
Color Softcopy Presentation State Storage	1.2.840.10008.5.1.4.1.1.11.2	Implicit VR Little Endian *See note	1.2.840.10008.1.2
		Explicit VR Little Endian *See note	1.2.840.10008.1.2.1
		Explicit VR Big Endian *See note	1.2.840.10008.1.2.2
		JPEG 2000 Image Compression *See note	1.2.840.10008.1.2.4.91
Basic Text SR	1.2.840.10008.5.1.4.1.1.88.11	Implicit VR Little Endian *See note	1.2.840.10008.1.2
		Explicit VR Little Endian *See note	1.2.840.10008.1.2.1
		Explicit VR Big Endian *See note	1.2.840.10008.1.2.2
		JPEG 2000 Image	1.2.840.10008.1.2.4.91

<b>Abstract Syntax Name</b>	<b>Abstract Syntax UID</b>	<b>Transfer Syntax Name</b>	<b>Transfer Syntax UID</b>
		Compression *See note	
Enhanced SR	1.2.840.10008.5.1.4.1.1.88.22	Implicit VR Little Endian *See note	1.2.840.10008.1.2
		Explicit VR Little Endian *See note	1.2.840.10008.1.2.1
		Explicit VR Big Endian *See note	1.2.840.10008.1.2.2
		JPEG 2000 Image Compression *See note	1.2.840.10008.1.2.4.91
Comprehensive SR	1.2.840.10008.5.1.4.1.1.88.33	Implicit VR Little Endian *See note	1.2.840.10008.1.2
		Explicit VR Little Endian *See note	1.2.840.10008.1.2.1
		Explicit VR Big Endian *See note	1.2.840.10008.1.2.2
		JPEG 2000 Image Compression *See note	1.2.840.10008.1.2.4.91
Chest CAD SR	1.2.840.10008.5.1.4.1.1.88.65	Implicit VR Little Endian *See note	1.2.840.10008.1.2
		Explicit VR Little Endian *See note	1.2.840.10008.1.2.1

Abstract Syntax Name	Abstract Syntax UID	Transfer Syntax Name	Transfer Syntax UID
		Explicit VR Big Endian *See note	1.2.840.10008.1.2.2
		JPEG 2000 Image Compression *See note	1.2.840.10008.1.2.4.91
X-Ray Radiation Dose SR	1.2.840.10008.5.1.4.1.1.88.67	Implicit VR Little Endian *See note	1.2.840.10008.1.2
		Explicit VR Little Endian *See note	1.2.840.10008.1.2.1
		Explicit VR Big Endian *See note	1.2.840.10008.1.2.2
		JPEG 2000 Image Compression *See note	1.2.840.10008.1.2.4.91
Breast Tomosynthesis Image Storage	1.2.840.10008.5.1.4.1.1.13.1.3	Implicit VR Little Endian *See note	1.2.840.10008.1.2
		Explicit VR Little Endian *See note	1.2.840.10008.1.2.1
		Explicit VR Big Endian *See note	1.2.840.10008.1.2.2
		JPEG 2000 Image Compression *See note	1.2.840.10008.1.2.4.91
Spatial	1.2.840.10008.5.1.4.1.1.66.1	Implicit VR	1.2.840.10008.1.2

Abstract Syntax Name	Abstract Syntax UID	Transfer Syntax Name	Transfer Syntax UID
Registration Storage		Little Endian *See note	
		Explicit VR Little Endian *See note	1.2.840.10008.1.2.1
		Explicit VR Big Endian *See note	1.2.840.10008.1.2.2
		JPEG 2000 Image Compression *See note	1.2.840.10008.1.2.4.91
Deformable Spatial Registration Storage	1.2.840.10008.5.1.4.1.1.66.3	Implicit VR Little Endian *See note	1.2.840.10008.1.2
		Explicit VR Little Endian *See note	1.2.840.10008.1.2.1
		Explicit VR Big Endian *See note	1.2.840.10008.1.2.2
		JPEG 2000 Image Compression *See note	1.2.840.10008.1.2.4.91
Mammography CAD SR	1.2.840.10008.5.1.4.1.1.88.50	Implicit VR Little Endian *See note	1.2.840.10008.1.2
		Explicit VR Little Endian *See note	1.2.840.10008.1.2.1
		Explicit VR Big Endian *See note	1.2.840.10008.1.2.2

Abstract Syntax Name	Abstract Syntax UID	Transfer Syntax Name	Transfer Syntax UID
		JPEG 2000 Image Compression *See note	1.2.840.10008.1.2.4.91
OB-GYN Ultrasound Procedure Reports	1.2.840.10008.5.1.4.1.1.88.5000	Implicit VR Little Endian *See note	1.2.840.10008.1.2
		Explicit VR Little Endian *See note	1.2.840.10008.1.2.1
		Explicit VR Big Endian *See note	1.2.840.10008.1.2.2
		JPEG 2000 Image Compression *See note	1.2.840.10008.1.2.4.91
Procedure Log	1.2.840.10008.5.1.4.1.1.88.40	Implicit VR Little Endian *See note	1.2.840.10008.1.2
		Explicit VR Little Endian *See note	1.2.840.10008.1.2.1
		Explicit VR Big Endian *See note	1.2.840.10008.1.2.2
		JPEG 2000 Image Compression *See note	1.2.840.10008.1.2.4.91
Vascular Ultrasound SR	1.2.840.10008.5.1.4.1.1.88.5100	Implicit VR Little Endian *See note	1.2.840.10008.1.2

Abstract Syntax Name	Abstract Syntax UID	Transfer Syntax Name	Transfer Syntax UID
		Explicit VR Little Endian *See note	1.2.840.10008.1.2.1
		Explicit VR Big Endian *See note	1.2.840.10008.1.2.2
		JPEG 2000 Image Compression *See note	1.2.840.10008.1.2.4.91
Enhanced MR Color Image Storage	1.2.840.10008.5.1.4.1.1.4.3	Implicit VR Little Endian *See note	1.2.840.10008.1.2
		Explicit VR Little Endian *See note	1.2.840.10008.1.2.1
		Explicit VR Big Endian *See note	1.2.840.10008.1.2.2
		JPEG 2000 Image Compression *See note	1.2.840.10008.1.2.4.91

IntelPACS supports storage of images with 8, 16, and 32 bits allocated.

 Images with 32 bits allocated will not be archived to tape.

- ☰ The IntelPACS server accepts a MPEG2 Main Profile @ High Level transfer syntax with UID of 1.2.840.10008.1.2.4.101, a MPEG2 Main Profile @ Main Level transfer syntax with a UID of 1.2.840.10008.1.2.4.100, a RLE Lossless transfer syntax with a UID of 1.2.840.10008.1.2.5, a JPEG Lossless, Non-Hierarchical, First-Order Prediction transfer syntax with UID of 1.2.840.10008.1.2.4.70, a JPEG 2000 Lossless Only with a UID of 1.2.840.10008.1.2.4.90 syntax, a JPEG Baseline (Process 1) with a UID of 1.2.840.10008.1.2.4.50 syntax, or a JPEG Extended (Process 2,4) with a UID of 1.2.840.10008.1.2.4.51 syntax to accommodate requirements of the SCU. This is established during a configuration step.
- ☰ The IntelPACS can store images for Enhanced CT. Also, it can store data encoded in these transfer syntaxes: MPEG (transfer syntaxes 1.2.840.10008.1.2.4.100 and 1.2.840.10008.1.2.4.101), RLE (transfer syntax 1.2.840.10008.1.2.5), and non-JPEG YBR (Photometric Interpretation YBR\_FULL\_422, YBR\_FULL, YBR\_PARTIAL\_422, YBR\_PARTIAL\_420, YBR\_ICT, YBR\_RCT with non-JPEG transfer syntax).
- ☰ For related information on the types of images and modalities that can be displayed by IntelPACS, see the *IntelViewer DICOM Conformance Statement*.
- ☰ The Enhanced MR Color Image Storage 1.2.840.10008.5.1.4.1.1.4.3 SOP will be enabled by default and can be disabled in configuration.

## SOP Specific Conformance—Storage

The server implements Level 2 (Full) conformance for the Storage SOP Class. The following attributes are modified by converting all characters to upper case before data is stored in the image database. The image files are modified, however a record of all changes is kept.

- Patient Name
- Patient ID
- Accession Number
- Study ID
- Study Description
- Referring Physician Name
- Series Description

In the event that an image is successfully stored by the server, it may be accessed by requesting associations with the server and performing Query/Retrieve operations.

The server returns the following status values in response to a C-STORE request:

- 0000H: Image successfully stored
- A700H: Refused, out of resources (unable to create local file)
- A900H: Error, data set does not match SOP Class
- C000H: Error, cannot understand

In the event of a storage error, the server returns one of the follow in the Error Comment field:

- PARSE ERROR: The server was unable to parse the image.
- DATABASE MISMATCH: The server has stored this UID in a different relation.
- UNKNOWN ERROR: Any other storage failure.

In the case of an error storing an image, there is no documented method for recovery. The onus is on the storage SCU to retry the operation and/or to report failure of the storage operation.

## **Presentation Context Acceptance Criterion**

The server accepts any number of storage SOP classes that are listed in Table 4 above, provided that the requesting application is known to the server and has been enabled to store images on the server (via a configuration step). The server defines no limit on the number of presentation contexts accepted. In the event that the server runs out of resources when trying to accept multiple presentation contexts, the server rejects the association request.

The server does not check for duplicate presentation contexts and will accept duplicate presentation contexts.

## **Transfer Syntax Selection Policies**

The server supports these transfer syntaxes for storage:

- Implicit VR Little Endian
- Explicit VR Little Endian

The presentation context that the IntelPACS accepts depends on the order of the proposed presentation contexts. If there are no matching presentation contexts then the association will be rejected.

The IntelPACS can be configured to accept these transfer syntaxes if the SCU allows them:

- JPEG 2000 Image Compression, Lossless or Lossy (1.2.840.10008.1.2.4.91)
- Explicit VR Big Endian (1.2.840.10008.1.2.2)
- JPEG Baseline, Process 1 (1.2.840.10008.1.2.4.50)
- JPEG Extended, Process 2,4 (1.2.840.10008.1.2.4.51)
- JPEG Lossless, Process 14 (1.2.840.10008.1.2.4.57)
- JPEG Lossless, Non-Hierarchical, First-Order Prediction (1.2.840.10008.1.2.4.70)
- JPEG 2000 Lossless Only. (1.2.840.10008.1.2.4.90)
- MPEG2 Main Profile @ High Level (1.2.840.10008.1.2.4.101)
- MPEG2 Main Profile @ Main Level (1.2.840.10008.1.2.4.100)
- MPEG-4 AVC/H.264 @ High Profile (1.2.840.10008.1.2.4.102)
- MPEG-4 AVC/H.264 BD-compatible @ High Profile (1.2.840.10008.1.2.4.103)
- RLE Lossless (1.2.840.10008.1.2.5)

## Real-World Activity Query/ Retrieve

### Associated Real-World Activity—Query/Retrieve

The server accepts associations from nodes that wish to perform query (find) and retrieve (move) operations on images that have been previously stored by the server.

The real-world activity associated with C-FIND and C-MOVE requests are the query and retrieval operations initiated by another application. An application other than the server queries the server for patient, study, series and image information that has been previously stored by the server and can request that the server send images to a third application entity.

A Master Database/Web server supports only queries for patient, study and series information.

### Presentation Context Table

Table 5 shows the presentation contexts that may be accepted by an IntelPACS server for query operations. These presentations contexts require no extended negotiation.

Acceptable Presentation Contexts for Query Classes

Abstract Syntax		Transfer Syntax		Role
Name	UID	Name	UID	
Patient Root Query/Retrieve	1.2.840.10008.5.1.4.1.2.1.1	Implicit VR	1.2.840.10008.1.2	SCP

Abstract Syntax		Transfer Syntax		Role
Name	UID	Name	UID	
Information Model – FIND		Little Endian		
Patient Root Query/Retrieve Information Model –MOVE	1.2.840.10008.5.1.4.1.2.1.2	Implicit VR Little Endian	1.2.840.10008.1.2	SCP
Study Root Query/Retrieve Information Model – FIND	1.2.840.10008.5.1.4.1.2.2.1	Implicit VR Little Endian	1.2.840.10008.1.2	SCP
Study Root Query/Retrieve Information Model –MOVE	1.2.840.10008.5.1.4.1.2.2.2	Implicit VR Little Endian	1.2.840.10008.1.2	SCP
Patient/Study Only Query/Retrieve Information Model – FIND	1.2.840.10008.5.1.4.1.2.3.1	Implicit VR Little Endian	1.2.840.10008.1.2	SCP
Patient/Study Only Query/ Retrieve Information Model – MOVE	1.2.840.10008.5.1.4.1.2.3.3	Implicit VR Little Endian	1.2.840.10008.1.2	SCP

### SOP Specific Conformance for SOP Class Query/Retrieve

Table 6 below indicates which keys are supported by the server for the Patient Root Information Model. The server also supports the Study Root and Patient/Study Only Information Models. The keys supported for the Patient/Study Information Model are the same keys found in Table 6 with a level of "Patient" or "Study".

### Keys Supported for Patient Root Information Model

Level	Description	Tag	Type
Patient	Patient Name	0010 0010	R
Patient	Patient ID	0010 0020	U
Patient	Patient Birth Date	0010 0030	O
Patient	Patient Birth Time	0010 0032	O
Patient	Patient Sex	0010 0040	O
Study	Study Date*	0008 0020	R
Study	Study Time*	0008 0030	R
Study	Accession Number	0008 0050	R
Study	Study ID	0020 0010	R
Study	Study Instance UID	0020 000D	U
Study	Referring Physician Name	0008 0090	O
Study	Study Description	0008 1030	O
Study	Patient's Age	0010 1010	O
Study	Patient's Size	0010 1020	O
Study	Patient's Weight	0010 1030	O
Series	Modality	0008 0060	R
Series	Series Number	0020 0011	R
Series	Series Instance UID	0020 000E	U
Series	Body Part Examined	0018 0015	O
Image	Image Number	0020 0013	R
Image	SOP Instance UID	0008 0018	U
Image	SOP Class UID	0008 0016	O
Image	Samples Per Pixel	0028 0002	O
Image	Rows	0028 0010	O
Image	Columns	0028 0011	O
Image	Bits Allocated	0028 0100	O
Image	Bits Stored	0028 0101	O
Image	Pixel Representation	0028 0103	O

\* If extended negotiation of combined Date/Time matching is successful, then a pair of Attributes that are a date and a time, both of which specify the same form of range matching, shall have the concatenated string values of each range matching component matched as if they were a single datetime Attribute.

Table 7 indicates which keys are supported by the server for the Study Root Information Model. These tables include the optional and required keys that are supported. Optional keys are supported like required keys. The server does not support relational queries.

Keys Supported for Study Root Information Model

Level	Description	Tag	Type
Study	Study Date	0008 0020	R
Study	Study Time	0008 0030	R
Study	Accession Number	0008 0050	R
Study	Patient Name	0010 0010	R
Study	Patient ID	0010 0020	R
Study	Study ID	0020 0010	R
Study	Study Instance UID	0020 000D	U
Study	Referring Physician Name	0008 0090	O
Study	Study Description	0008 1030	O
Study	Patient Birth Date	0010 0030	O
Study	Patient Birth Time	0010 0032	O
Study	Patient Sex	0010 0040	O
Study	Patient's Age	0010 1010	O
Study	Patient's Size	0010 1020	O
Study	Patient's Weight	0010 1030	O
Study	Requested Procedure ID	0040 1001	O
Series	Modality	0008 0060	R
Series	Series Number	0020 0011	R
Series	Series Instance UID	0020 000E	U
Series	Body Part Examined	0018 0015	O
Image	Image Number	0020 0013	R

Level	Description	Tag	Type
Image	SOP Instance UID	0008 0018	U
Image	SOP Class UID	0008 0016	O
Image	Samples Per Pixel	0028 0002	O
Image	Rows	0028 0010	O
Image	Columns	0028 0011	O
Image	Bits Allocated	0028 0100	O
Image	Bits Stored	0028 0101	O
Image	Pixel Representation	0028 0103	O

## Presentation Context Acceptance Criterion

The server accepts any number of query SOP classes that are listed in Table 5 above, provided that the requesting application is known to the server and has been enabled to make requests from the server (via a configuration step). The server defines no limit on the number of presentation contexts accepted. In the event that the server runs out of resources when trying to accept multiple presentation contexts, the server rejects the association request.

The server does not check for duplicate presentation contexts and will accept duplicate presentation contexts.

## Transfer Syntax Selection Policies

An IntelPACS server only supports the Implicit VR Little Endian transfer syntax. Any proposed presentation context which includes the Implicit VR Little Endian transfer syntax will be accepted with the Implicit VR Little Endian transfer syntax. Any proposed presentation context that does not include the Implicit VR Little Endian transfer syntax will be rejected.

## Real-World Activity Verification

### Associated Real-World Activity—Verification

The server accepts associations from nodes that wish to perform a verification operation on the server.

The real-world activity associated with the C-ECHO request is that an external node wishes to verify network or server operation without initiating any actual work.

## Presentation Context Table

The following table shows the presentation contexts that may be accepted by an IntelPACS server for verification operations. These presentation contexts require no extended negotiation.

Presentation Contexts for Verification

Abstract Syntax		Transfer Syntax		Role
Name	UID	Name	UID	
Verification	1.2.840.10008.1.1	Implicit VR Little Endian	1.2.840.10008.1.2	SCP

### SOP Specific Conformance—Verification

Echo SCP provides standard conformance to the Verification Service Class.

### Presentation Context Acceptance Criterion

The server accepts any number of verification SOP classes that are listed in Table 8 above, provided the requesting application is known to the server (via a configuration step). The server defines no limit on the number of presentation contexts accepted. In the event that the server runs out of resources when trying to accept multiple presentation contexts, the server rejects the association request.

The server does not check for duplicate presentation contexts and will accept duplicate presentation contexts.

### Transfer Syntax Selection Policies

The server only supports the Implicit VR Little Endian transfer syntax. Any proposed presentation context which includes the Implicit VR Little Endian transfer syntax will be accepted with the Implicit VR Little Endian transfer syntax. Any proposed presentation context that does not include the Implicit VR Little Endian transfer syntax will be rejected.

## Real-World Activity—Storage

### Associated Real-World Activity—Storage

The IntelPACS server accepts associations from nodes that wish to store images using the C-STORE command.

The associated Real-World activity associated with the C-STORE operation is the storage of the image on the disk of the system upon which the server is running. Images are stored by writing the data set of the C-STORE command directly to disk. Images headers are modified under the following circumstances:

- The server is performing storage of teaching files. In this case, the Patient Name field is replaced by the text BLANK^NAME.
- The server detects a violation of the DICOM standard in a unique identifier, for example a leading zero in a multi-digit element of a Study, Series or SOP Instance UID. In this case, the server attempts to repair the UID while preserving uniqueness.
- The server retrieves RIS information for the current study during a validation step and that information conflicts with demographics present in the images. In this case, the server substitutes the RIS values into the DICOM elements.
- The server is configured to re-map specific DICOM header fields to other fields.
- The server is configured to write the calling Application Entity Description into the element Institutional Department Name (0008 1040).
- The server is configured to write its AE Title, the AE Title and Organization of the calling Application Entity (SCU), MD5Sum, Histogram, Largest and Smallest Pixel Value, into private tags.
- The server is configured to convert YBR (specifically, YBR FULL and YBR FULL 422) images to RGB.

After the image is stored to disk, the server updates an image database with patient, study, series and image information. This information is used by the server for Query/Retrieve operations.

Image database patient, study, series and location information are transferred to one or more central master databases located on Master Database/Web Servers. Series location information consist primarily of the Series Instance UID for the image set, the Application Entity Title of the C-STORE SCP (the server) and the number of images in the series.

The server issues a failure status if it is unable to store the image on disk, if the image does not conform to the IOD of the SOP class under which it was transmitted, or if the server is not able to successfully update its image database.

Duplicate images, those with a SOP Instance UID already stored on the server are accepted and silently ignored. Images must be explicitly deleted from the server before they can be replaced with altered copies.

## Presentation Context Table

The following table shows the presentation contexts that may be accepted by an IntelPACS server for Storage Commitment operations. These presentation contexts require no extended negotiation.

Acceptable Presentation Contexts for an IntelPACS Server for Storage Commitment

Abstract Syntax		Transfer Syntax		Role
Name	UID	Name	UID	
Storage Commitment Push	1.2.840.10008.1.20.1	Implicit VR Little Endian	1.2.840.10008.1.2	SCP

### SOP Specific Conformance—Storage

The server implements Level 2 (Full) conformance for the Storage SOP Class. The following attributes are modified by converting all characters to upper case before data is stored in the image database. The image files are modified, however a record of all changes is kept.

- Patient Name
- Patient ID
- Accession Number
- Study ID
- Study Description
- Referring Physician Name
- Series Description

In the event that an image is successfully stored by the server, it may be accessed by requesting associations with the server and performing Query/Retrieve operations.

The server returns the following status values in response to a C-STORE request:

- 0000H: Image successfully stored
- A700H: Refused, out of resources (unable to create local file)
- A900H: Error, data set does not match SOP Class
- C000H: Error, cannot understand

In the event of a storage error, the server returns one of the follow in the Error Comment field:

- PARSE ERROR: The server was unable to parse the image.
- DATABASE MISMATCH: The server has stored this UID in a different relation.
- UNKNOWN ERROR: Any other storage failure.

In the case of an error storing an image, there is no documented method for recovery. The onus is on the storage SCU to retry the operation and/or to report failure of the storage operation.

## **Presentation Context Acceptance Criterion**

The server accepts any number of storage SOP classes that are listed in Table 4 above, provided that the requesting application is known to the server and has been enabled to store images on the server (via a configuration step). The server defines no limit on the number of presentation contexts accepted. In the event that the server runs out of resources when trying to accept multiple presentation contexts, the server rejects the association request.

The server does not check for duplicate presentation contexts and will accept duplicate presentation contexts.

## **Transfer Syntax Selection Policies**

The server only supports the Implicit VR Little Endian transfer syntax. Any proposed presentation context which includes the Implicit VR Little Endian transfer syntax will be accepted with the Implicit VR Little Endian transfer syntax. Any proposed presentation context that does not include the Implicit VR Little Endian transfer syntax will be rejected.

## **Real-World Activity Modality Worklist**

### **Associated Real-World Activity—Modality Worklist**

The Modality Worklist Application Entity is configured with one or more modality worklists based on information obtained from the RIS. For each configured worklist, the AE builds a list of worklist information objects which can be queried through the Modality Worklist Information Model – FIND SOP Class. The client AE accesses its worklist by supplying the worklist name as the called Application Entity Title (the title of the Modality Worklist SCP). In this way, the server can host an unlimited number of separate worklists accessible by one or more SCUs.

Information is obtained from the RIS for orders in a specific state (Patient Arrived) and for a pre-configured sliding date/time range based on the Scheduled Procedure Step Date and Time.

## Presentation Context Table

The following table shows the presentation contexts that may be accepted by an IntelPACS server for Modality Worklist service requests. These presentation contexts require no extended negotiation.

Acceptable Presentation Contexts for an IntelPACS Server for Modality Worklist

Abstract Syntax		Transfer Syntax		Role
Name	UID	Name	UID	
Modality Worklist – FIND	1.2.840.10008.5.1.4.31	Implicit VR Little Endian	1.2.840.10008.1.2	SCP

## SOP Specific Conformance—Modality Worklist

The following table shows the keys or elements accepted by the server as search criteria.

Keys Supported for Modality Worklist Information Model—  
FIND

Description	Tag	Type
Patient Name	0010 0010	O
Patient ID	0010 0020	O
Accession Number	0008 0050	O
Scheduled Station AE Title	0040 0001	O
Scheduled Procedure Step Start Date	0040 0002	O
Scheduled Procedure Step Start Time	0040 0003	O
Modality	0008 0060	O

The following table shows the elements provided in the Modality Worklist Information Model – FIND response.

Elements Available in Modality Worklist Information  
Model—FIND

Description	Tag
Accession Number	0008 0050
Referring Physician Name	0008 0090
Patient Name	0010 0010
Patient ID	0010 0020

Description	Tag
Patient Birth Date	0010 0030
Patient Sex	0010 0040
Study Instance UID	0020 000d
Requested Procedure Description	0032 1060
Requested Procedure Code Sequence	0032 1064
> Procedure Code	0008 0100
Scheduled Procedure Step Sequence	0040 0100
> Modality	0008 0060
> Scheduled Station AE Title	0040 0001
> Scheduled Procedure Step Start Date	0040 0002
> Scheduled Procedure Step Start Time	0040 0003
> Scheduled Procedure Step ID	0040 0009
Requested Procedure ID	0040 1001

## Presentation Context Acceptance Criterion

The server accepts Modality Worklist service requests from any application when the called Application Entity Title used represents a configured Modality Worklist on the server.

## Transfer Syntax Selection Policies

The server only supports the Implicit VR Little Endian transfer syntax. Any proposed presentation context which includes the Implicit VR Little Endian transfer syntax will be accepted with the Implicit VR Little Endian transfer syntax. Any proposed presentation context that does not include the Implicit VR Little Endian transfer syntax will be rejected.

# 5

## COMMUNICATION PROFILES

### **TCP/IP Stack**

The server provides DICOM V3.0 TCP/IP Network Communication Support as defined in Part 8 of the DICOM Standard.

### **TCP/IP API**

The server uses the TCP/ IP stack from the Unix system upon which it executes. It uses a sub-routine library that is based on a Berkeley socket interface.

### **Physical Media Support**

The server exists as software applications that can be compiled on various Unix platforms and utilities that require a Perl interpreter. However, the preferred platform of implementation and the only one for which operational versions are routinely supplied is Linux on ix86 (Intel). Implementation places no restrictions on the physical network. The server has been demonstrated using TCP/IP over Ethernet (Thick Wire, Thin Wire, UTP) at speeds of 10, 100, and 1000 Mbit/s.

# 6

## EXTENSIONS/SPECIALIZATIONS/PRIVATIZATIONS

There are currently no extensions, specializations, or privatizations.

# OBTAINING PRINTED DOCUMENTATION

Intelrad offers printed and bound versions of product documentation free of charge. To request printed copies of Intelrad documentation, contact your Client Success manager. The printed documents will be provided within 7 days or less.

# CONTACTING INTELERAD TECHNICAL SUPPORT

Your PACS administrator can assist you with any issues you may encounter. If you require additional assistance, you can contact Intelrad Technical Support, 24 hours a day, seven days a week.

To contact us:	Use:
On the Internet	<a href="https://serviceportal.intelerad.com/csm">https://serviceportal.intelerad.com/csm</a>
By telephone	Toll-free North America, UK, and Ireland: 1-866-951-6222 United Kingdom: 0113-360-2615 Sans frais Amérique du Nord (français): 1 844-467-7227 Toll-free Australia: 1-800-286-418 Toll-free New Zealand: 0800-467-723 Other: +1-514-931-7127

These coordinates and a wealth of other information are also available on the Intelrad Service Portal.

<https://serviceportal.intelerad.com/csm>

You should regularly check the Intelrad knowledge base for the latest version of the documentation, as well as other product-specific resources such as TechNotes, downloads, and videos.

When you contact Intelrad Technical Support to report a problem, please have at hand the following information, as applicable:

- client code and location of your IntelePACS installation
- full error message and the steps required to reproduce the problem
- AE Titles of the affected devices
- operating systems of any affected machines
- description of the problem and when it first occurred

If the problem affects a particular study, please also provide the following:

- patient ID or patient number (M.R.N.)
- accession number/requisition number
- modality type and name

# SYSTEM REQUIREMENTS

For more information on system requirements, you can contact Intelrad Technical Support or access the *Intelrad Workstation and Accessories Recommendations Guide* by using the Intelrad Service Portal:

<https://serviceportal.intelerad.com/csm>

- ☰ A medical device such as IntelPACS must be supported and maintained to be used under applicable authority regulations. If your IntelPACS is not accessible to Intelrad's Technical Support, Intelrad will not provide maintenance (including remote monitoring, remote diagnostics, and maintenance). IntelPACS is a medical device, and as such, must meet medical device safety and effectiveness requirements imposed by national regulations. The Client is advised that using IntelPACS without access from Intelrad's Technical Support may put the health and safety of patients at risk, as the Client may not be advised of the availability of software patch, bug fix, update or upgrade, nor will be informed of Field Safety Notices, Medical Device Recalls, or Advisory Notices related to IntelPACS. Furthermore, Intelrad will not be in a position to have access to the Client's systems to implement corrections to prevent occurrences of patient safety issues. Any use of the Licensed Software beyond Intelrad's standard support practice is client's own responsibility.